

Austrian Space Programme

> asap >

Projects - 3th and 4th Call for Proposals

Photo: ESA/Metop

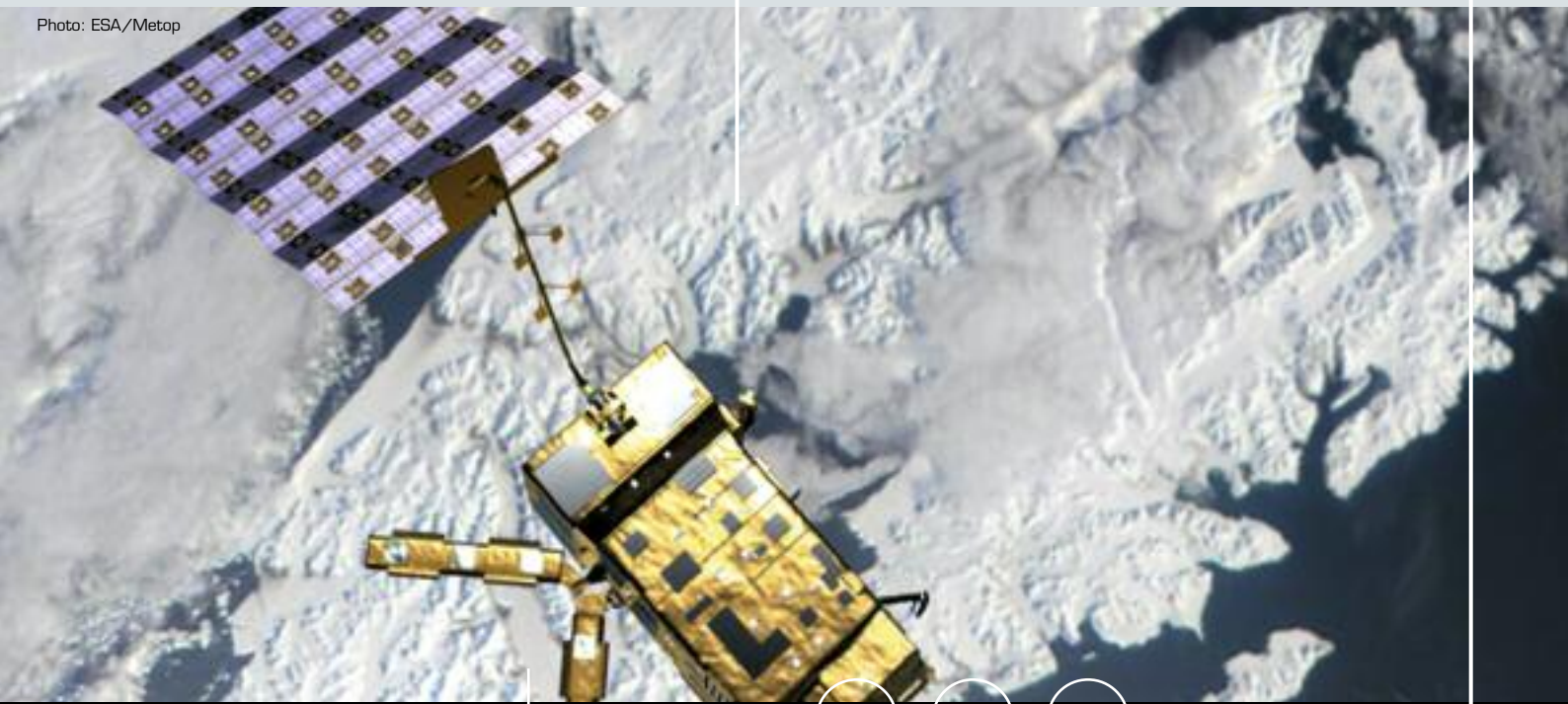

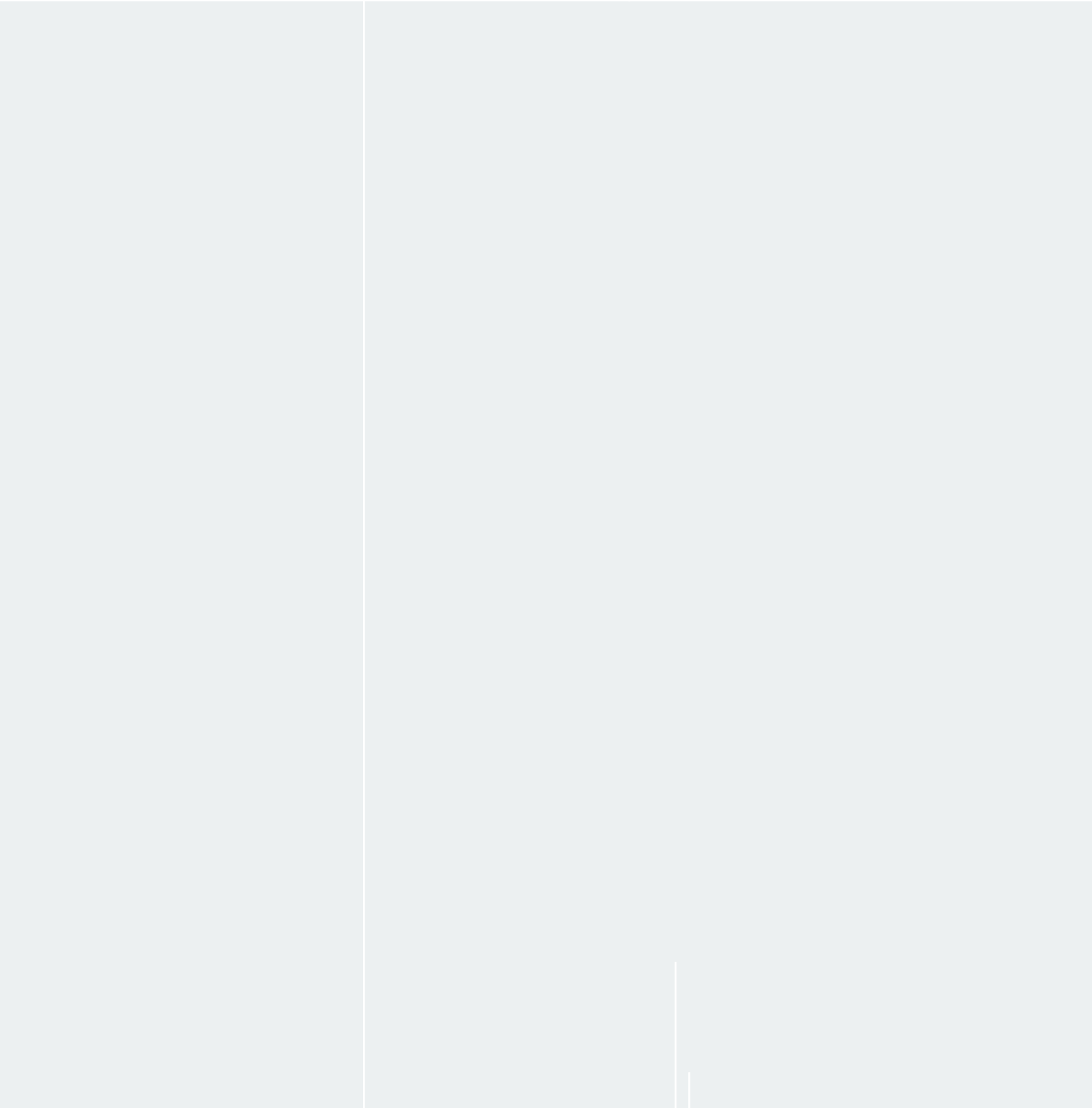

Preface

*All truths are easy to understand
once they are discovered;
the point is to discover them.*

Galileo Galilei, Italian astronomer & physicist (1564-1642)

In recent years space has moved high up the political agenda in Europe. Considering space as a strategic asset and both a source of inspiration and innovation, Europe, for the first time, agreed on a space policy in 2007. The new vision adds a space dimension to the European Union policies focussing on space applications for the benefit of Europe's citizens and yields a new European Union's dimension to international space cooperation.

In 2006 Austria contributed actively to the building of the European Space Policy with the Graz Dialogue, a Conference under its EU-Presidency, bringing in the regional dimension to the Global Monitoring for Environment and Security GMES, an initiative of the European Union and the European Space Agency ESA. Following this initiative, several EU-Presidencies followed up and organized events highlighting several aspects of GMES, which will be built up gradually to deliver information services to the area of environment and security.

Within these emerging strategies and facing new challenges of the future, Austrian science research and industry have developed and made valuable contributions to European missions and have acquired an excellent reputation in this field.

Supported by the Austrian Space Programme, Austria wants to reach technological and scientific excellence, build critical mass at national level, cooperate internationally, and involve new Austrian players in space activities. As a general strategy, focus is laid on applications of space technologies in particular on the promising fields of Earth observation and satellite navigation.

A new possibility for the Austrian community is the participation of the Austrian Space Programme in the first pilot call for proposals of the ERA-STAR Regions under the ERA-NET scheme of the 6th Framework Programme of the European Commission in 2006. This new form of cooperation in particular with the regions bordering Austria has been well received by the Austrian community.

The folder you hold in your hands continues the series of publications about the results of the Austrian Space Programme. It offers the complete range of the third and fourth call for proposals from 2005 to 2006. It is a vivid sign of the broad expertise and the success of the Austrian space community and of the national funding sustainability. It is my particular pleasure to show you the broad spectrum of Austrian contributions to the space endeavour.



A handwritten signature in black ink that reads "Doris Bures". The signature is fluid and cursive.

Doris Bures
Federal Minister
Austrian Federal Ministry for Transport,
Innovation and Technology

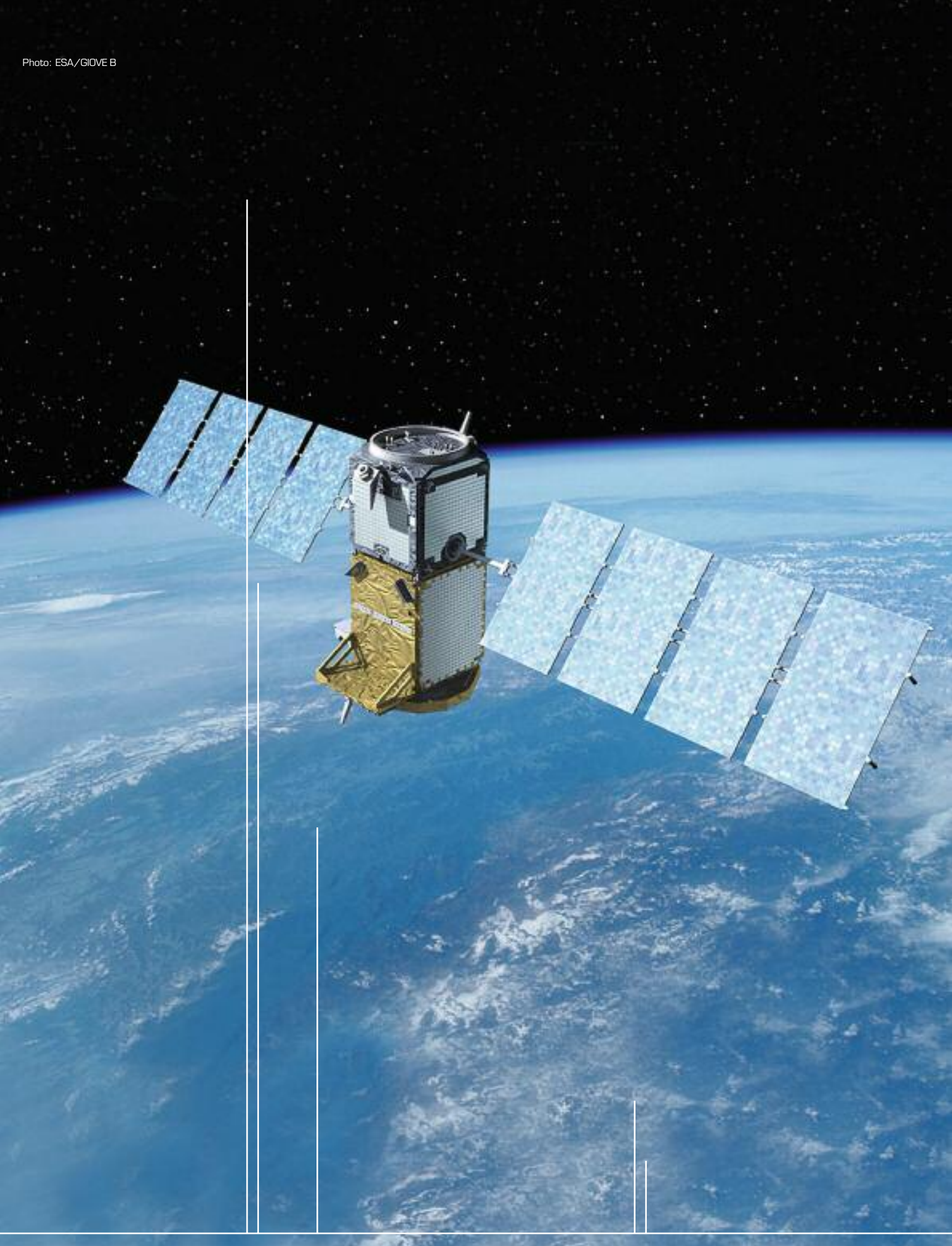

Content

Austrian Space Programme	6	ODILIA	37
Earth Observation	8	POMAR 3D	38
ACCURaid	9	PPos-Taxi	39
ALS-X	10	SANOWA	40
EO- KDZ (EO-CCD)	11	SKISPRUNG	41
EO-NatHaz	12	SPEF	42
EOPSLIM	13	SVEQ	43
EO-TEN	14	Space Science	44
HWRM	15	BRITE-AUSTRIA	45
KuX-SAR	16	GEOOnAUT	46
MULTICLIM	17	INDIUM	47
OMI-ASAP	18	MERMAG	48
PAT+	19	PICAM	49
REBECCA	20	Resonance	50
Human Spaceflight, Microgravity and Exploration	21	TMIS.plus.II	51
Electrical Resistivity	22	Space Technology	52
ExoMars PanCam 3D	23	µPPT Development	53
HALOSPACE	24	GATE	54
MATSIM Phase-A	25	LEO-SLR	55
METTRANS	26	SALOTTE	56
SERMER	27	USI – Phase 1	57
Launcher	28	VEDW	58
FLEX	29	Telecommunications	59
Navigation	30	CASIMO2	60
AUSPRO	31	GS M&C	61
BALANCE	32	NEST	62
DIGSTER Go & Map	33	SIECAMS BOX	63
eGame	34	ERA-Star Regions	64
GALIMET	35	Contacts	67
GNSS-MET	36		

Austrian Space Programme



Programme Description

Since its creation in 2002, the Austrian Space Programme has seen two more calls for proposals in 2005 and 2006 respectively. In 2005 the Austrian Space Programme included the Austrian Radionavigation Technology and Integrated Satnav Services and Products Testbed (ARTIST). A new programme element was created – Direct Applications of Space Technologies – to underline the increasing importance of space applications and the potential value added by integrating space technologies into terrestrial technologies. This new possibility encountered an excellent response within the Austrian community.

In addition to that the Austrian Space Programme participated in the first pilot call for proposals of the ERA-NET ERA-STAR Regions in 2006. ERA-NET is a scheme within the 6th Framework Programme of the European Commission for Research and Technological Development. ERA-STAR Regions is a network of public funding organisations which supports programmes in the field of space applications (GALILEO, GMES & Technology Applications). It comprises 12 European regions and medium-sized nations. Austria participated on a large scale, compared to other countries, and two transnational projects were started. This possibility adds a new dimension to cooperation with regions bordering to Austria.

Key elements of the programme

Main Objectives

- > Position Austrian players on the commercial market
- > Support specialisation and networking
- > Create technological content
- > Improve scientific excellence

Approach

- > Bottom-up
- > Project-oriented
- > Funding lead projects (cooperative projects)
- > Competitive
- > Applying Best Practice Code for Evaluation
- > Internationally oriented
- > Sustainable
- > Complementing international activities

Programme Elements

- > Science
- > Technology
- > International programmes
- > Space technology transfer
- > Direct applications of space technology





Programme Elements

Science

This programme element strengthens Austrian competence in space science and research by supporting the participation of Austrian experts in international scientific programmes. It also promotes Austrian contributions to the European Space Agency's Science Programme.

Technology

This programme element aims at developing commercial products and services on the basis of shared funding PPP, thus complementing activities of European and international space programmes. It includes regulations of shared funding for project applicants comparable to those applied in similar ESA programmes and is subsidiary to various European and international space programmes.

International Programmes

This programme element supports bilateral and multilateral activities and enables the Austrian space community to take substantial steps towards becoming systems developers and producers, helping them to position themselves effectively on international markets.

Space Technology Transfer

This programme element supports highly specialised activities in the field of space technology transfer in order to contribute more actively to the dissemination of technologies to other sectors and vice versa. These activities are coordinated with the corresponding ESA and EU activities.

Direct Applications of Space Technology

This programme element focuses on direct applications of space technology, e.g. possible future applications and services of the European satellite system GALILEO, telecommunications, earth observation and the integration of two or more space technologies into other technologies.



Target Group

The Austrian Space Programme addresses Austrian and international scientists, scientific institutions, industrial enterprises and other companies, including SMEs located in Austria.

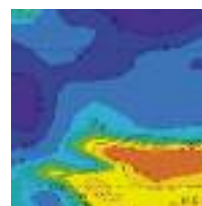

Earth Observation

ACCURAITD

ALS-X

EO- KDZ (EO-CCD)

EO-NatHaz

EOPSCLIM

EO-TEN

HWRM

KuX-SAR

MULTICLIM

OMI-ASAP

PAT+

REBECCA

ACCURRAID

Aid to ACCURATE Climate Satellite Mission Preparations for Backing the Austrian Leading Role

ACCURATE (Atmospheric Climate and Chemistry in the UTLS Region And climate Trends Explorer) is a next generation climate mission concept conceived at the Wegener Center/Uni Graz, which was proposed in 2005 by an international team of more than 20 partners from more than 12 countries to an ESA (European Space Agency) selection process for the next Earth Explorer Missions. Within a stringent peer assessment process it received very positive evaluation and recommendations for further study. Based on this, the concept undergoes scientific performance analyses as well as technical preparations on instrumentation.

ACCURATE employs the occultation measurement principle, known for its unique combination of high vertical resolution, accuracy and long-term stability, in a novel way in a Low Earth Orbit (LEO) inter-satellite configuration. It combines use of highly stable signals in the microwave 17-23/178-200 GHz bands (LEO-LEO MW occultation) with laser signals in the short-wave infrared 2-2.5 micron band (LEO-LEO IR laser occultation).

The parameters observed include fundamental atmospheric variables from the MW bands (temperature, pressure, humidity), complemented by line-of-sight wind and six key greenhouse gases (GHGs) and chemistry species from the SWIR band (H₂O, CO₂, CH₄, N₂O, O₃, CO; and main CO₂ and H₂O isotopes). ACCURATE is set to provide benchmark data for future monitoring of climate, GHGs, and chemistry changes of unprecedented quality, including the first height-resolved atmospheric measurements of CO₂ and its isotopes (allowing to separate anthropogenic from natural CO₂ sources) with global coverage.

In order to back the Austrian scientific leading role on ACCURATE, the project ACCURRAID initiated an assessment of the scientific utility and performance of the novel LEO-LEO IR laser occultation part of ACCURATE; the LEO-LEO MW occultation part had already been studied to some extent in previous ESA study work. Focussing on this, ACCURRAID was a crucial preparatory and accompanying study in the context of ACCURATE mission development. In particular, two main lines of work were pursued: 1) enhancement of an end-to-end radio and MW occultation simulation tool ("EGOPS") for enabling quasi-realistic simulations of IR laser occultation data as well, 2) initial end-to-end analysis of the performance for GHG and isotope profile retrievals from these IR data.

Infobox

Project duration:

01.03.2006 – 30.4.2007

Coordinator:

Wegener Center for Climate and Global Change
University of Graz, Prof. Gottfried Kirchengast

www.wegcenter.at

A-8010 Graz, Leechgasse 25

Mail: gottfried.kirchengast@uni-graz.at

Partner(s):

Institute of Atmospheric Physics, Prof. Ulrich Schumann
DLR Oberpfaffenhofen, Munich

www.dlr.de/pa/

Department of Chemistry, University of York, U.K.

www.york.ac.uk/depts/chem/

Prof. Peter Bernath

Department of Atmospheric Sciences

University of Arizona, Tucson, Prof. E. Robert Kursinski

www.atmo.arizona.edu

and other Members of the International ACCURATE Team (more than 20 partners from more than 12 countries) and Members of ESA/ESTEC Technical Staff (Future Missions Division/Earth Observation Programmes) for specific ESA-related questions

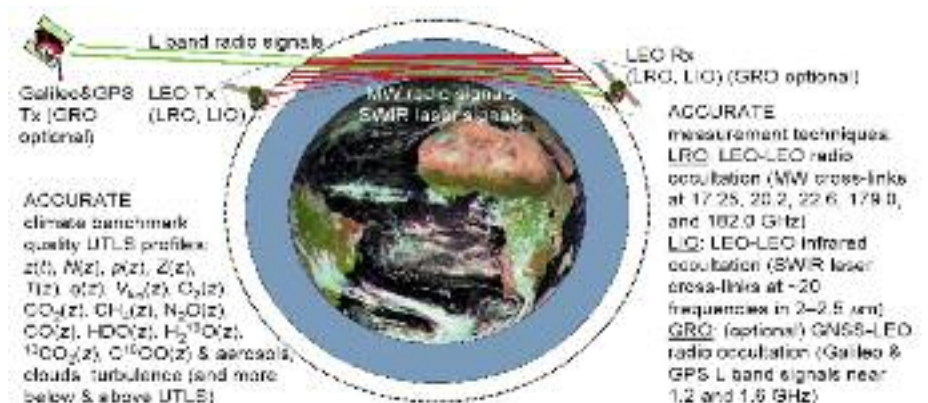

ALS-X

Combination and Evaluation of Airborne Laser Scanning Data and TerraSAR-X Data for Glacier and Snow Monitoring

Due to their close and rather direct relationship to atmospheric energy and material fluxes, mountain glaciers are perfect indicators for the ongoing global climate change. Both the high point density (1 point/m² or higher as a standard value), which allows a very detailed terrain representation, and the extraordinary vertical accuracy of about $\pm 10\text{cm}$ has made airborne laser scanning become a standard method for the acquisition of topographical data for glaciological purpose.

The project aims at analysing and evaluating time synchronous airborne laser scanning data and TerraSAR-X satellite data under glaciological and snow hydrological aspects. Therefore, four laser scanning data acquisition campaigns have been carried out at Hintereisferner and Kesselwandferner (Tyrol) during the glaciological year 2007/2008. Besides the comparison of the two data types, it is a further objective of this project to continue the worldwide unique time series of laser scanning data originating back to 2001. Based on the laser scanning data both DEMs (Digital Elevation Models) and surface classification maps are calculated, compared and evaluated with relevant TerraSAR-X data products. In-situ data from field campaigns during the EO data acquisition contribute to the validation of the results.

Furthermore, a concept for an efficient monitoring strategy with integrated airborne and satellite EO data will be developed, with particular consideration of end-user requirements (glacier ski resorts, power authorities).



Infobox

Project duration:

01.10.2007 – 31.03.2009

Coordinator:

Johann Stötter

Institute of Geography

University of Innsbruck

A-6020 Innsbruck

Telephon: +43 (0)512-507 5403

Email: hans.stoetter@uibk.ac.at

Web: www.uibk.ac.at/geographie

Partner:

Institute of Meteorology

University of Innsbruck

Univ.- Prof. Dr. Michael Kuhn

Web: www.uibk.ac.at/meteorologie

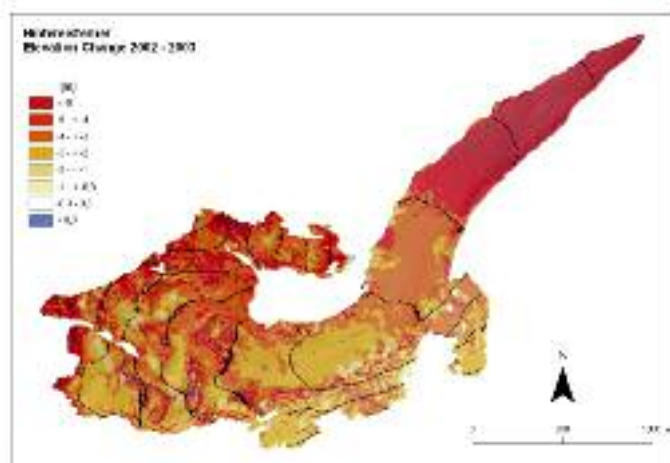

EO-KDZ (EO-CCD)

Development of an Earth Observation Based Regional Centre for Crisis Data

The increase in natural disasters, humanitarian crises, and civil risks leads to a strong demand in actual geoinformation. Experiences in recent years have shown that such kind of geoinformation needs to be given immediately before the events and often over large areas. Sources answering to these information needs are earth observation data collected during or close to the events on the one hand, and information collected in the field via GNSS-based mobile mapping data on the other hand. Implemented via a centre for crisis data, they offer effective tools to assess crises, but also offer information for crisis prevention and reconstruction.

The project Development of an earth observation based regional centre for crisis data

(EO-CCD) therefore aimed at conceptually designing an earth observation based regional centre for crisis data, which integrates all relevant components of geoinformation. One task of the centre is the rapid acquisition, processing and analysis of satellite data and mobile mapping data in the field of natural disasters and civil protection.

Relevant development tasks for the realisation of the centre for crisis data comprised:

- Definition of requirements regarding the centre for crisis data in collaboration with the user group (State Government of Vorarlberg and the Tyrol, TIWAG).
- Development of the conceptual design of the centre and its components taking also into account its technical hard- and software implementation and the definition of the expert team operating in the centre.
- Evaluation of the different earth observation satellites regarding their implementation facilities for disaster monitoring and crisis management.
- Set-up of a catalogue with satellite-specific data acquisition guidelines to be used in case of activation of the crisis data centre.
- Evaluation of mobile mapping data regarding their implementation facilities for disaster monitoring and crisis management.
- Definition of interfaces and formats of satellite data, mobile mapping data and further auxiliary data
- Development and adaptation of methods for the generation of user defined information products and services in the field of crisis management and civil protection.

With the development of the centre for crisis information an integrated mobile data processing and geoinformation platform will be available, which can be activated in crisis situations e.g. caused by natural hazards.

Infobox

Project duration:

01.03.2007 – 29.02.2008

Coordinator:

Frederic Petrini-Monteferri

GRID-IT Gesellschaft für angewandte Geoinformatik mbH

A-6020 Innsbruck, Technikerstr. 21a

Telephone: +43 (0)512-507 4860

Email: petrini@grid-it.at

Web: www.grid-it.at

Partners:

alpS – Zentrum für Naturgefahren

Dr. Eric Veulliet

Web: www.alps-gmbh.com

Universitätszentrum Rottenmann

Dr. Klaus Aichhorn

Web: www.uzr.at

Institute of Geography, University of Innsbruck

Univ.- Prof. Dr. Friedrich Schöberl

Web: www.uibk.ac.at/geographie/



EO-NatHaz

Assessment of Potential Damage and Risk Exposure Caused by Natural Hazards with Earth Observation

In Austria, a large part of residential areas, infrastructure, commercial and industrial buildings are potentially put at risk by natural catastrophes (e.g. floods, avalanches, storms) due to their highly exposed locations, particularly in mountainous areas. For the treatment of insurance claims, but also for public help funds and organisations it is of utmost interest to get information about the risk exposure and to assess the potential economic loss or damage of buildings and artificial objects in case of catastrophic events.

EO-NatHaz has the objective to explore and exploit the utility of novel space based remote sensing techniques – on the one hand for the assessment of potential damages and economic losses and on the other hand for the derivation of risk exposures due to natural hazards.

Development is done in co-operation with stakeholders on the user side (Forsttechnischer Dienst für Wildbach- und Lawinenverbauung, Vorarlberger Landesregierung, Landesvermessung samt Vorarlberg, Stand Montafon). The project also serves to exploit the commercial opportunities arising from continuous data availability from the radar satellite TerraSAR-X. Experience in research and space science, applied research as well as commercial implementation and application development are the complementary EO-NatHaz project partner assets. Accordingly, the technical work content has been conceived in a manner to fully exploit these capabilities.

Besides an improvement of key EO and modelling techniques, EO-NatHaz will deliver information components providing critical input into an expert system on damage and loss potential. Furthermore, end-users will receive EO derived information components serving their specific expert systems on risk exposure.

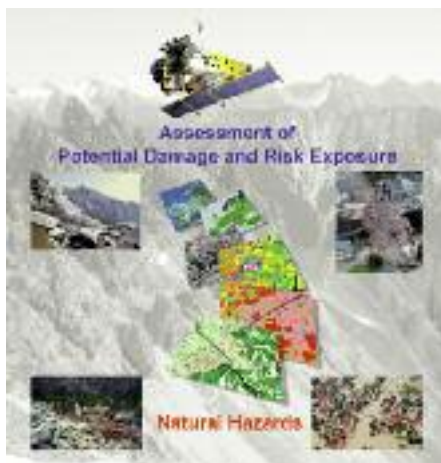

Infobox

Project duration:

01.01.2007 - 01.10.2008

Coordinator:

Christian Hoffmann

GeoVille Information Systems Group GmbH

A - 6020 Innsbruck, Museumstraße 9 – 11, Austria

Phone: +43 (0)512 56 20 21 – 0

Fax: +43 (0)512 56 20 21 - 22

email: hoffmann@geoville.com

Internet: www.geoville.com

Partners:

Austrian Research Centers GmbH – ARC

Klaus Steinnocher

www.systemsresearch.ac.at

TU Wien – Institute of Photogrammetry and Remote Sensing, Wolfgang Wagner

www.ipf.tuwien.ac.at/welcome.html

Forsttechnischer Dienst für Wildbach- und Lawinenverbauung, www.die-wildbach.at

Vorarlberger Landesregierung, www.vorarlberg.at

Landesvermessungsamt Vorarlberg

www.vorarlberg.at/vorarlberg/bauen_wohnen/bauen/landesvermessungsamt/start.htm

Stand Montafon

www.stand-montafon.at/stand-montafon/

Infoterra

www.infoterra.de

EOPSCLIM

End-to-End Occultation Processing System and Climate Monitoring Service: MetOp GRAS and ACCURATE Integration

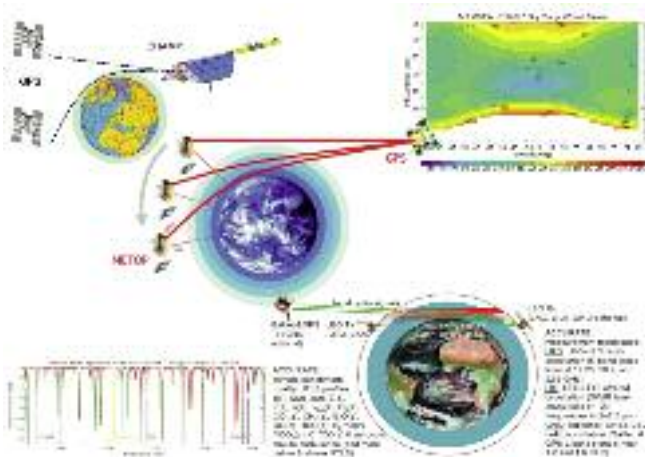

The provision of carefully validated radio occultation (RO) climatologies from the new European MetOp satellites (MetOp-A launched in October 2006) is of key interest to climate research, since these RO observations derived from navigation signals of the Global Positioning System (GPS) allow to retrieve fundamental variables of the Earth's atmosphere (temperature, pressure, humidity) with unprecedented accuracy and consistency. Complementarily, preparing for future occultation systems, the ACCURATE (Atmospheric Climate and Chemistry in the UTLS Region and Climate Trends Explorer) mission conceived at the Wegener Center/Uni Graz is a next-generation climate mission concept adding greenhouse gas and wind measurement information (see the ACCURATE project overview for more information). Further developing this concept is of key interest to enable future occultation systems to provide unprecedented benchmark observations of greenhouse gas increases and related climate change.

In this context, the EOPSCLIM project contributes to research along three main lines:

- 1) Validation of MetOp GRAS data by using data from other research RO missions as well as ECMWF analyses, and set-up of regional climate monitoring based on RO data for IPCC regions
- 2) Advancement of the new ACCURATE infrared laser occultation functionality within the WegCenter's end-to-end occultation simulator system ("EGOPS") by aerosol modeling and by a first version of wind profile retrieval processing
- 3) Contribution to the integration of real RO data processing within the EGOPS system, focusing on the new MetOp GRAS data stream.

Infobox

Project duration:

01.04.2007 – 30.04.2008

Coordinator:

Wegener Center for Climate and Global Change
University of Graz

www.wegcenter.at

Prof. Gottfried Kirchengast

A-8010 Graz, Leechgasse 25

Mail: gottfried.kirchengast@uni-graz.at

Partners:

GNSS Atmosphere Sounding Group

GFZ Potsdam, Germany

www.gfz-potsdam.de/pb1/GASP/

Dr. Jens Wickert

Meteorological Division

EUMETSAT Darmstadt, Germany

www.eumetsat.int

Dr. Axel von Engel

COSMIC Project Office, UCAR Boulder, CO, U.S.A.

www.cosmic.ucar.edu

Dr. Bill Kuo

Goddard Space Flight Center, NASA Greenbelt, MD, USA

www.nasa.gov/centers/goddard

Dr. Christian Retscher

In addition to its vital contributions to further development of the ACCURATE concept and to MetOp GRAS validation in the framework of the ESA/EUMETSAT MetOp Research Announcement of Opportunity, EOPSCLIM, for the first time, makes available RO based regional climate monitoring over the official IPCC regions (about two dozen land regions world-wide in Africa, Europe, Asia, North America, Central and South America, Australia and New Zealand, complemented by polar and oceanic regions). This opens a new avenue of exploiting RO data for regional climate change diagnosis.



EO-TEN

Earth Observation Applications for Trans European Networks



EARTH OBSERVATION APPLICATIONS FOR TRANS EUROPEAN NETWORKS

The Brenner Axis has recently been designated a priority number one project among 30 Trans European Network (TEN) projects representing a total of € 225 billion investment up to 2020. To minimise environmental impacts of TEN projects, legal instruments such as the Environmental Impact Assessment (EIA) and the Strategic Environmental Assessment (SEA) have to be applied prior to construction.

EO-TEN has the objective to increase the operational application potential of innovative Earth observation (EO) methods having a realistic market potential in Austria and Europe for EIAs and SEAs. The focus is on improving and advancing EO methods and derived products serving to protect the environment, the population and the infrastructure itself and to develop a sustainable service component serving EIAs and SEAs.

Development is done in co-operation with stakeholders on the user side (Brenner Eisenbahn Gesellschaft BEG, Austrian Umweltbundesamt) and involvement of Leica Geosystems, the world's leading image processing software company. Experience in research and space science, applied research as well as commercial implementation and application development are the complementary EO-TEN project partner assets.

EO-TEN thematically complements the current GMES involvement of the project partners, where Austria has secured the leading role in space based spatial planning applications until 2012. As such EO-TEN addresses a niche market opportunity, which has not been covered in GMES yet, but offers significant commercial contract opportunities. Integrated exploitation with the ESA-GSE Land project will provide market access to stakeholders in 12 European countries.

Besides an improvement of key EO techniques, EO-TEN outcomes comprise EO derived maps, geo-information and analysis results in the domains of land cover, settlement structures, environmental and landscape monitoring, terrain

Infobox

Project duration:

01.04.2006 - 01.11.2007

Coordinator:

Christian Hoffmann

GeoVille Information Systems Group GmbH

A-6020 Innsbruck, Museumstraße 9 – 11, Austria

Phone: +43 (0)512 56 20 21 – 0

Fax: +43 (0)512 56 20 21 - 22

email: hoffmann@geoville.com

Internet: www.geoville.com

Partners:

Austrian Research Centers GmbH – ARC

Klaus Steinnocher, Florian Kessler

www.systemsresearch.ac.at

TU Wien – Institute of Photogrammetry and Remote Sensing

Wolfgang Wagner, Markus Hollaus

www.ipf.tuwien.ac.at/welcome.html

Leica Geosystems

www.leica-geosystems.com

structures, and surface displacement. These results will allow for systematic and geospatial explicit environmental analyses in the SEA and EIA framework. With these results the consortium and users will have significant information and tools for minimising environmental impacts of TEN projects, and protecting the population and the infrastructure.



People affected by the corridor planning



HWRM

Hydrology and Water Resources Management – HWRM New Satellite Techniques for Hydrology and Water Management of Alpine Regions

The project supports the scientific preparations for the CoRe-H₂O mission (COld REgions Hydrology High-resolution Observatory). CoRe-H₂O was proposed to ESA by an international team under the lead of H. Rott (ENVEO) in response to the 2005 Call for Ideas for the next ESA Earth Explorer Core missions. The mission was selected by ESA for further technical and scientific studies. CoRe-H₂O addresses the need for improved, spatially detailed measurements of snow and ice from regional to global scales in order to advance the understanding of the role of the cryosphere in the climate system and to improve the knowledge and prediction of water cycle variability and changes in cold environment.

CoRe-H₂O features an innovative sensor, a dual polarized, dual frequency (Ku- and X-band) imaging radar (SAR). These short radar wavelengths are particularly sensitive to physical properties of snow and ice. The main objective of the project HWRM is the development of methods for retrieval of snow and ice parameters from Ku- and X-band SAR measurements.

The development work is based on field experiments and theoretical backscatter modelling. Forward models were applied to study the sensitivity of the different frequencies and polarizations for measuring physical properties of snow and ice and to develop concepts for inversion of the radar measurements. Several field campaigns with airborne scatterometer and ground-based SAR were carried out in winter 2006/07 in the Austrian Alps and in Colorado in cooperation with the international project partners. Prototype algorithms for retrieval of snow and ice parameters from high frequency SAR have been developed. Sample snow and ice data products have been produced from airborne test data sets and from satellite-borne scatterometry to demonstrate the performance of the inversion algorithms.

The project results are of great importance for scientific preparation of the CoRe-H₂O mission. The work is also very relevant for improved Earth Observation based services in hydrology and water management of mountain areas and snow covered regions, as addressed by GMES and the climate observing system GCOS.

The project is carried out in co-operation with

- Institute for Computational Earth System Science (ICESS), University of California, CA, USA
- eOsphere Ltd, West Woodhay Newbury Berkshire, UK
- National Operational Hydrologic Remote Sensing Center NOHRSC, NWS / NOAA, Chanhassen, MN, USA
- NASA / JPL, Pasadena, CA, USA
- Department of Aerospace, Power and Sensors, University of Cranfield, Swindon, UK

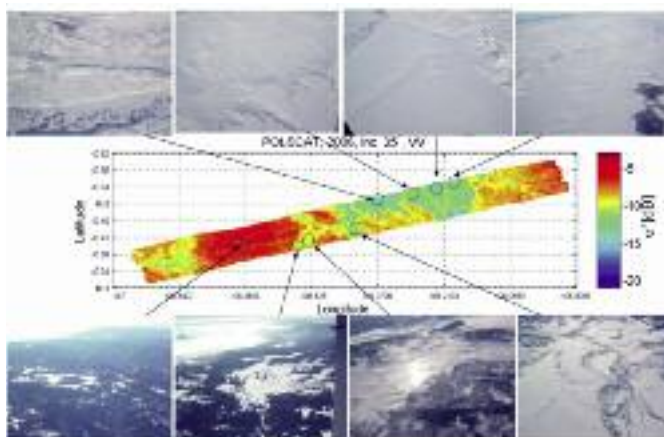

Infobox

Project duration:

01.07.2006 – 31.12.2007

Coordinator:

ENVEO – Environmental Earth Observation IT GmbH
6020 Innsbruck, Technikerstr. 21a

Email: office@enveo.at

www.enveo.at



KuX-SAR

Preparing for New High Frequency SAR Missions

The project prepares for the operational and scientific utilization of new high frequency imaging radar (SAR) missions: the X-band SAR missions TerraSAR-X and COSMO-SkyMed, both launched in June 2007, and the TanDEM-X mission (scheduled for launch in 2009). The project partners are involved in international activities for the new satellites as members of Science Teams and as leaders of AO projects. In addition, the project supports the scientific preparation for the dual frequency (Ku- and X-band SAR) mission CoRe-H₂O, COld REgions Hydrology High-resolution Observatory. CoRe-H₂O was proposed to ESA by an international team under the lead of H. Rott in response to the 2005 Call for Ideas for ESA Earth Explorer Core missions and was selected for Pre-Phase-A study.

The thematic focus of the project is on two important applications of high resolution SAR:

- Snow and ice observations for water management and climate research
- The retrieval of forest parameters

The work at ENVEO deals with development of methods for retrieval of snow and glacier parameters from the new SAR data. To support and test these developments, ENVEO participated in field experiments with airborne scatterometry in Austria and Alaska in winter 2007/08. In addition, snow and ice sample products, generated from TerraSAR-X data and scatterometry, are applied in snow hydrology and glacier mass balance models to investigate the information content of the new sensors.

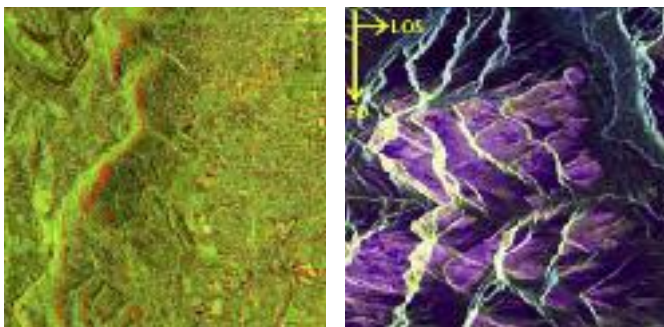

The work at JR-DIB deals with the development of methods, processing strategies and algorithms for the retrieval of anthropogenic changes on the one hand, and mapping of natural hazards like subsidence or storm damage at a basic level on the other. Therefore, stereo-radargrammetric as well as interferometric mapping techniques are adapted and tuned with respect to the characteristics of the high-resolution TerraSAR-X data. For these data, semi-automated mapping procedures and concepts for end-to-end processing lines are expected to become readily available by this project.

Infobox

Project duration:

01.07.2007 – 31.12.2008

Coordinator:

ENVEO Environmental Earth Observation IT GmbH
6020 Innsbruck, Technikerstr. 21a

Tel: + 43-512-50748-30

Email: office@enveo.at

www.enveo.at

Partner:

Joanneum Research

8010 Graz, AT

www.joanneum.at



The synergy in the methods for SAR data processing for the two applications addressed by ENVEO and JR-DIB, is exploited by joint methodological developments. The project achievements related to forest parameter retrieval support pan European and regional assessment of forest distribution and condition with respect to GMES Core Services in GEOLAND 2 and future Downstream Services. The snow and ice component is very relevant for global cryosphere monitoring in the proposed GMES Core Service on Climate Change and for Downstream Services in water management and hydrology.

This project is carried out in co-operation with the following partners:

- INFOTERRA GmbH, Friedrichshafen, Germany
- Institut für Hochfrequenztechnik und Radarsysteme, DLR, Oberpfaffenhofen, Germany
- National Operational Hydrologic Remote Sensing Center NOHRSC, NWS / NOAA, Chanhassen, MN, USA
- Institute of Oceanography, Center for Marine and Climate Research, Universität Hamburg, Hamburg, Germany
- NASA / JPL, Pasadena, CA, USA



MULTICLIM

From CHAMP towards Multi-Satellite Climate Monitoring Based on the MetOp and COSMIC Missions

The overarching goal of the MULTICLIM project was to prepare for global monitoring of the climate evolution of the Earth's atmosphere with high accuracy and consistency and thereby help to improve the ability to detect, attribute, and predict climate variability and change. The key datasets for this purpose are radio occultation data (CHAMP, COSMIC, MetOp missions) and Infrared Atmospheric Sounder Interferometer (IASI) data (from MetOp), of which the latter were in the focus of the MULTICLIM project.

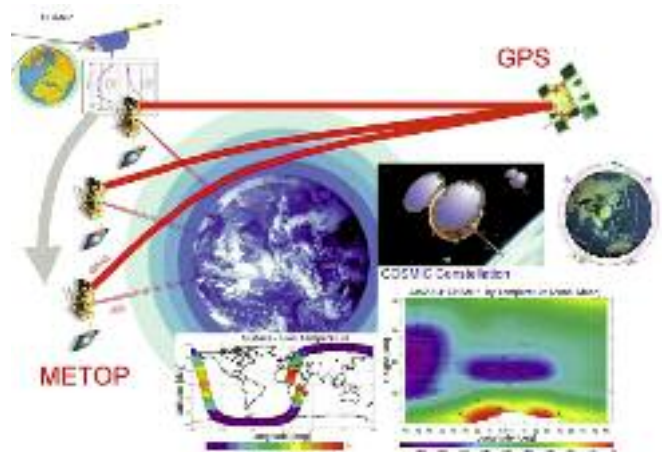

One of the primary objectives of the IASI sensor on board the European MetOp satellites (the first satellite MetOp-A being in orbit since October 2006) is the improvement of the vertical resolution of temperature and water vapor profiles to about 1–2 km in the troposphere as well as to improve the retrieval accuracy to within 1 K in temperature and about 10% in humidity. A main scientific motivation for this is the key role played by water vapor in the upper troposphere and its effects on the global climate, since only small changes in humidity and its trends have serious implications on the amount of thermal energy escaping to space and thus on the strength of the Earth's greenhouse effect. IASI is expected to supply more accurate quantification of climate variability and change and, additionally, the IASI data promise to greatly assist numerical weather prediction in delivering accurate and frequent temperature and humidity profiles for operational meteorology needs.

Contributing in the framework of the joint ESA and EUMETSAT MetOp Research Announcement of Opportunity, the MULTICLIM project undertook to advance IASI retrieval algorithms and to prepare IASI climatology processing for climatologies at high horizontal resolution, but also with horizontal grids matching radio occultation climatologies. Furthermore, retrieved temperature, humidity, and ozone profiles as well as sea surface temperature data from a "test orbit" of real MetOp IASI data were validated against co-located data from analysis fields of the European Centre for Medium-Range Weather Forecasts (ECMWF).

The project was valuable in contributing to the validation of IASI data during the MetOp-A satellite commissioning phase as well as it paved the way to further advancement and broader application of the IASI retrieval system for climate studies.

Infobox

Project duration:

01.03.2006 – 30.11.2007

Coordinator:

Wegener Center for Climate and Global Change
University of Graz

www.wegcenter.at

Prof. Gottfried Kirchengast

A-8010 Graz, Leechgasse 25

Mail: gottfried.kirchengast@uni-graz.at

Partners:

Meteorological Division, EUMETSAT Darmstadt
www.eumetsat.int

Dr. Peter Schlüssel

European Centre for Medium-Range Weather Forecasts
ECMWF Reading, U.K.

www.ecmwf.int

Dr. Marco Matricardi

Space Science and Engineering Center
University of Wisconsin, Madison

www.ssec.wisc.edu

Dr. Elisabeth Weisz



OMI-ASAP

Validation of Ozone Monitoring Instrument (OMI) Ground UV Products

Good quality UV maps are only achievable by using satellite information and satellite data. The present project deals with the validation of the UV products retrieved by the Ozone Monitoring Instrument (OMI) instrument on board of NASA/EOS AURA satellite. The project is closely connected to the ESA project (ID 2945) "Validation of OMI products over Europe with ground-based UV instruments". 4 work packages (WP) are identified within the scope of the project:

WP. 1: The UV maps over Europe are validated using the ground-based UV network consisting of several stations. Comparisons at these locations are performed on a routine basis by the owners of the instruments themselves. From these investigations, first statements about the accuracy of the OMI ground UV determination were made. This was done for Austria within the scope of the present project.

Within the scope of WP 2 campaigns with additional measurements were performed in Vienna and its surrounding in May 2007 and in Innsbruck and its surrounding from February to March 2008. Measurements were performed with 5 similar portable broadband detectors at 5 stations within the OMI footprint scale in Vienna and its surroundings. The representativeness of one value for one pixel as well as the subpixel variability were investigated. In Innsbruck and surroundings measurements of ground UV, as well as aerosol characteristics were performed. Special emphasis was put on the investigation of the effect of the topography on the ground UV and UV satellite retrieval.

In WP 3 special studies and analysis of the data were performed to investigate UV retrieval errors due to the influence of the tropospheric gases ozone, SO₂, NO₂ and of aerosols. In order to investigate and analyse/specify the effect of different pollutants and aerosols on UV irradiance, ground based measurements of environmental monitoring networks as well as aerosol parameters from the aerosol monitoring network AERONET were used as input parameters for radiative transfer simulations.

WP4: Using the campaign data and also additional measurements in the Viennese area and in the vicinity of Sonnblick observatory, the influence of regional inhomogeneity on UV retrieval and the question of the representativeness of one pixel value are addressed. Special attention is paid to (i) the influence of topography within one pixel, (ii) the influence of different ground albedo and ground structure.

Infobox

Project duration:

01.12.2007 – 30.06.2008

Coordinator:

University of Applied Life Sciences and Natural Resources,

1190 Vienna, Peter Jordan Straße 82

Prof. Philipp Weihs, weihs@mail.boku.ac.at

Partner:

University of Graz, Institute of Geophysics, Astrophysics and Meteorology, Austria

Dr. Erich Putz, erich.putz@kfunigraz.ac.at

Medical University of Innsbruck,

Biomedical Physics, Austria

Prof. Mario Blumthaler, mario.blumthaler@uibk.ac.at



Pléiades is a French Earth Observation satellite program carried out in cooperation with Austria, Belgium, Italy, Spain, and Sweden. Pléiades has also achieved the status of a "GMES Contributing Mission".

Two Pléiades satellites are being launched in 2010 and 2011 and are offering a spatial resolution at nadir of 0.7 m and a coverage capacity necessary for fine cartography needs, notably in urban regions. The Pléiades product list includes Ortho Images and Ortho Mosaics which due to their geographic map projections can be integrated into Geographic Information Systems (GIS). PAT+ is an innovative technology for online data access to the Pléiades Ortho Products covering large geographical areas and will be supplied by Austrian Research Centers GmbH – ARC. A requirements analysis and design study was carried out by ARC jointly with the designated Pléiades data distributor, the French company Spot Image. The current status of this development (spring 2008) is that ARC have completed the architectural design and interface specifications. Available pilot and critical component implementations confirm the technical feasibility of PAT+ and the envisaged online data access functions. ARC plan to deliver and integrate the PAT+ system for pre-launch operations starting in 2009.

PAT+ is uniquely designed in that it combines features for:

- ingestion of TerraByte-volume ortho products;
- storage in a so-called Coverage Repository (i.e. generation and management of PAT+ Products as aggregated geocoded grid coverages in multi-resolution image pyramids);
- viewing on the Internet via Web browser providing optimum user experience;
- direct access delivery of PAT+ Products to dedicated client or user application software systems; this includes functionality for back-tracing of product generation history based on meta data;
- Identity-centric user access management for implementation of data policy.

The PAT+ development enables ARC to continue a long-term international cooperation strategy with the developers of satellite Earth Observation interoperability infrastructure and user service systems. The perspective of PAT+ fits into the European initiative for Heterogenous Mission Access and related space standardization efforts which will be essential for the success of GMES.



Infobox

Project duration:

PAT+ Phase 1:

01.05.2006 – 31.12.2006

PAT+ Phase 2:

16.06.2007 – 18.12.2007

Coordinator:

Austrian Research Centers GmbH – ARC

Donau-City-Straße 1, 1220 Vienna, Austria

gerhard.triebning@arcs.ac.at

www.space-applications.at

Partner:

Spot Image, S.A., France

www.spotimage.com



REBECCA

Real-time Blending EPS-METEOSAT by Canonical Correlation Analysis

Two different types of satellites are currently used in operational meteorology:

- 1 The geostationary satellites of the "Meteosat Second Generation" (MSG) series, which deliver images of 12 spectral (visible and infrared) channels; these images are available every 15 minutes.
- 2) The polar-orbiting satellites, like MetOp-A of the EUMETSAT Polar System (EPS) that has been orbiting since 19 October 2006. Albeit the temporal resolution is much lower, EPS can reveal a lot of interesting details of the state of the atmosphere by virtue of (partly unique) instruments that deliver information about the vertical structure of the atmosphere (temperature and humidity profiles), about its chemical composition (trace gases) and about precipitation – all of them parameters which cannot be seen (directly) by MSG.

The question which arose is about a potential synergistic combination of satellite data of the geostationary orbit and those of the low earth orbit. The goal of this project is to develop a standardized procedure of merging those data which at first sight appear rather incompatible in terms of content, spatial and temporal availability. With the help of such a system, information of EPS should be extended in time and to such geographical regions where EPS is currently not available. The correlation with MSG channels within the overlapping areas shall provide the information necessary to simulate the EPS parameter.

Meteorological correlations are often dependent on season, time of day, latitude or the general synoptic situation. Especially the last one is hard to catch by conventional regressions. Therefore the employed methods do not search for average relations between meteorological variables, but – analyzing each image individually – are based on the most recently observed interdependencies. The prominent correlations and common patterns are sought in a more-dimensional data space by the help of eigentechniques, a group of sophisticated statistical methods (comprising principal component analysis, factor analysis, independent component analysis, canonical correlation analysis,...).

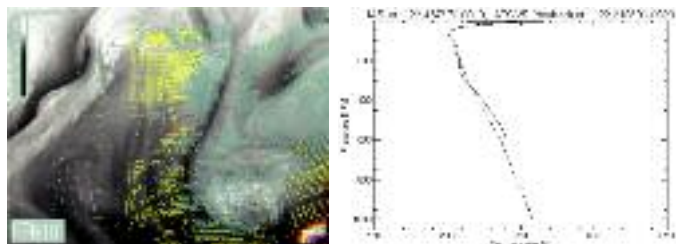

Infobox

01.07.2007 – 01.12.2008

Coordinator:

Zentralanstalt für Meteorologie und Geodynamik

Alexander Jann

1190 Wien, Hohe Warte 38

+43 1 360262316

alexander.jann@zamg.ac.at

www.zamg.ac.at

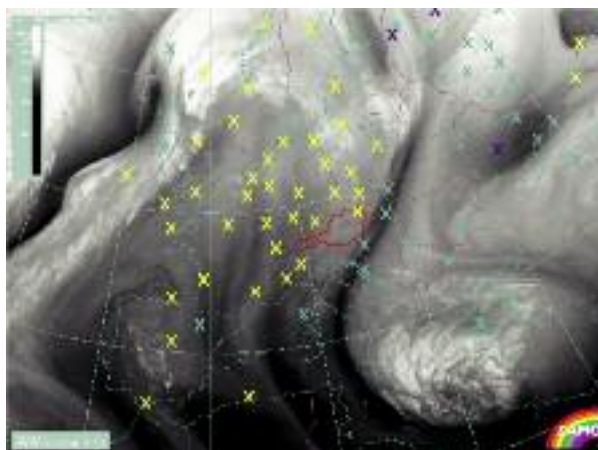
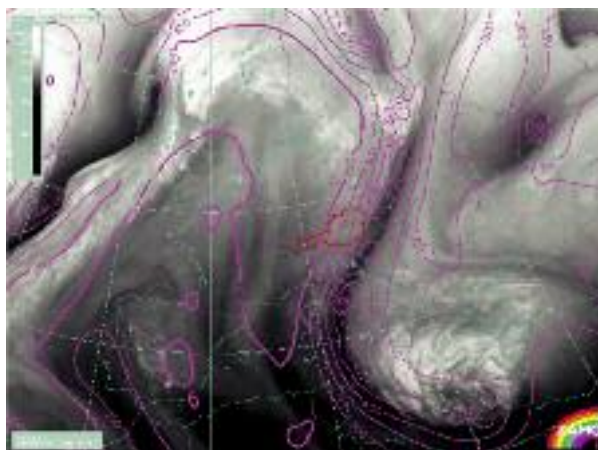

Human Spaceflight, Microgravity and Exploration

Electrical Resistivity

ExoMars PanCam 3D

HALOSPACE

MATSIM Phase-A

METTRANS

SERMER

Electrical Resistivity

Electrical Resistivity Measurement of High Temperature Metallic Melts

“Electrical Resistivity Measurement of High Temperature Metallic Melts” is the title of a collaboration project of the German Aerospace Center DLR and the Austrian TU Graz, represented by the Workgroup of Subsecond Thermophysics at the Institute of Experimental Physics.

The electrical resistivity of metallic melts is of obvious importance to many liquid metal processing operations, because it controls the melt flow under the influence of electromagnetic fields, e.g., during casting processes, or in crystal growth furnaces. Additionally, via the Wiedemann-Franz law, the knowledge of the temperature dependent electrical resistivity also enables an indirect determination of the temperature dependent thermal conductivity for many liquid metals without disturbances by any convective fluid flow in the sample.

For hot metallic melts containerless handling and measurement methods, as provided in the Materials Science Lab / Electromagnetic Levitator (MSL / EML) facility, are mandatory. In microgravity this facility yields an optimal experimental environment for our intention: The sample is not disturbed by external forces, which otherwise would lead to a distorted shape and to fluid flow in the melt. It is contained in a clean environment and can be processed over a large temperature range. The project is considered as preparation of a μg -experiment in the MSL / EML facility on board the International Space Station ISS. Results of these resistivity measurements shall be used as benchmarks for ground based measurement techniques, as e.g. the fast pulse heating technique.

The fast pulse heating technique is used to rapidly heat metallic samples from room temperature up to the liquid phase. This is achieved by discharging a capacitor-bank over the sample during a defined space of time (typically 50 μs). Heating rates of 108 K/s are reached and data of resistivity and enthalpy as a function of temperature are obtained. Because of that, interactions between the sample and its environment are negligible. Temperature is measured via the thermal radiation of the sample and the thermal expansion is quantified from CCD shadowgraph pictures.

A second part of this collaboration, already proposed as ASAP V project, will focus on measurements of alloys.

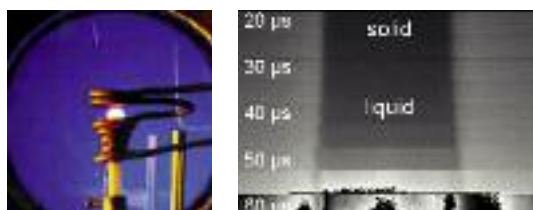

Infobox

Project duration:

01.11.2006 – 31.08.2008

Coordinator:

Prof. Dr. Gernot Pottlacher, TU Graz
Institute of Experimental Physics
8010 Graz, Petersgasse 16, Austria
phone: +43 (0) 316 873 – 8149
fax: +43 (0) 316 873 – 8655
Mail: pottlacher@tugraz.at
www.tugraz.at

Partners:

Dr. Georg Lohöfer,
Deutsches Zentrum für Luft- und Raumfahrt DLR,
Institut für Materialphysik im Weltraum
51170 Köln, Deutschland
phone: +49 (0) 2203 601 2565
fax: +49 2203 601 225
Mail: georg.lohoefer@dlr.de
www.dlr.de



ExoMars PanCam 3D

Three-Dimensional Vision for the Panoramic Camera on ExoMars Rover

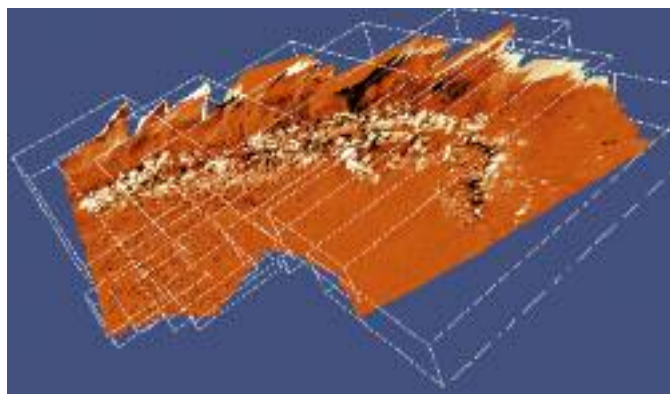

ESA's ExoMars Rover Mission, is scheduled for launch in 2013 and landing on the Red Planet in late 2014 to search for signs of past and present life on Mars. One important scientific sensor is a panoramic imaging system (PanCam) mounted on the ExoMars Rover Mast. It consists of a wide angle multispectral stereo pair and a high resolution monoscopic camera.

Main objectives during its six months operational phase are the provision of context information to detect, locate and measure potential scientifically interesting targets, localize the landing site, geologically characterize the local environment, and observe experiments. Three dimensional (3D) PanCam vision processing is an essential component of mission planning and scientific data analysis. Standard ground processing products will be digital terrain maps, panoramas, and virtual views of the environment.

The current development of such processing is carried out by the PanCam 3D Vision Team under JR co-ordination within the ASAP Projects "ExoMars PanCam-A" and "ExoMars PanCam 3D" with background coming from the Mars Netlander Panoramic Camera (DLR) and the Beagle 2 camera system (MSSL, JR, and Univ.Wales). Camera calibration, quality estimation of the expected results and the interfaces to other mission elements such as operations planning, rover navigation system and global Mars mapping are a specific concern of the current development.

After landing in 2014 the resulting software tools and their processing products will be used by geologists, exobiologists and mission engineers to decide upon experiments, select scientifically interesting sites for the rover, and determine risks, resource costs and a priori success probability of vehicle operations: PanCam 3D vision is a key element of ExoMars mission success.

Infobox

Project duration:

Current Development Phase
01.02.2006 – 31.12.2008

Coordination:

Institute of Digital Image Processing
Joanneum Research (JR), www.joanneum.at
DI Gerhard Paar
8010 Graz, Wastiangasse 6
Mail: gerhard.paar@joanneum.at

Main Partners:

Mullard Space Science Laboratory (MSSL)
University College London, Dr. Andrew Coates
www.mssl.ucl.ac.uk/www_plasma

German Aerospace Center (DLR)
Institute of Planetary Research, Berlin,
Dr. Ralf Jaumann
www.dlr.de/berlin

Department of Computer Science,
University of Wales, Aberystwyth, Dr. Dave Barnes
www.aber.ac.uk/compsci/Research/robots



HALOSPACE

Response of *Halococcus dombrowskii* Cells to the Space Environment and Preparation for Exposure Experiments on the International Space Station



The European Technology Exposure Facility (EuTEF) on the outside of the Columbus laboratory of the International Space Station (ISS) contains the subsection EXPOSE-E, which is currently used for five biological experiments. One of them is ADAPT, which is coordinated by Principal Investigator Dr. Petra Rettberg, DLR (German Aerospace Center), Köln, and contains an Austrian contribution called HALOSPACE.

The ADAPT experiment will compare the survival strategies and adaptation of three highly resistant microorganisms from different terrestrial habitats: a photosynthetic cyanobacterium, which is exposed to high levels of solar UV radiation in its natural environment, an extremely halophilic archaeobacterium, *Halococcus dombrowskii*, which was isolated from a 250 million year old alpine salt deposit near Bad Ischl, and *Bacillus subtilis*, a spore-forming soil bacterium. The preparation of samples and the analytical work involving *Hc. dombrowskii* are being carried out at the University of Salzburg. Cells of *Hc. dombrowskii* were deposited on quartz discs of 11 mm diameter and were accommodated into the sample holder. Due to their content of carotenoids, cells of *Hc. dombrowskii* are naturally of intense reddish pigmentation, which is thought to afford protection from strong UV radiation. To test this hypothesis, non-pigmented variants of *Hc. dombrowskii* cells, obtained by growth in different culture media, were also used in order to assess any differences in the extent of protection against cellular damage.

Infobox

Project duration:

01.04.2007 – 31.05.2008

Coordinator:

Prof. Dr. Helga Stan-Lotter

University of Salzburg

Division of Molecular Biology

Department of Microbiology

A-5020 Salzburg, Billrothstr. 11

Tel 0662 8044 7210

Email: helga.stan-lotter@sbg.ac.at

Web: www.uni-salzburg.at

Partner:

Dr. Petra Rettberg (Principal Investigator)

DLR, German Aerospace Center

Web: www.dlr.de/strahlenbiologie

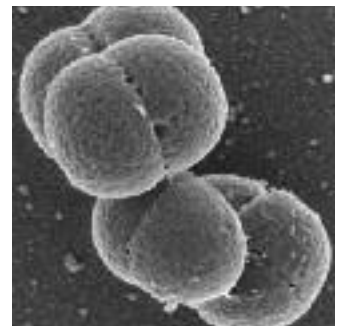
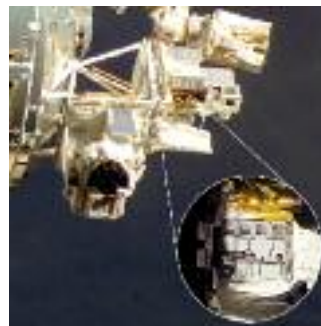

MATSIM Phase-A

Numerical Simulation of the Radiation Exposure of the MATROSHKA Phantom

The main aim of the MATSIM-Phase A project is to perform the full numerical simulation of the MATROSHKA phantom with the use of a Monte Carlo radiation transport code. The project is carried out within the framework of the already existing and acknowledged ESA ELIPS project MATROSHKA, an international collaboration of more than 18 research institutes from all over the world. MATROSHKA is an experiment designed to determine the radiation exposure of an astronaut during an extravehicular activity (EVA) at the International Space Station (ISS). For this purpose, several thousands passive and seven active radiation detectors measured the spatial dose distribution within an anthropomorphic phantom exposed outside the ISS (Figure Phantom).

The numerical modelling of the MATROSHKA phantom is done using the FLUKA Monte Carlo code to simulate the particles' transport and interaction with matter. The code can simulate with high accuracy the interaction and propagation of different particles in a wide energy range such as photons and electrons from 1 keV to thousands of TeV, hadrons up to 20 TeV and all the corresponding antiparticles, neutrons down to thermal energies, and heavy ions. The code can handle very complex geometries. A Computer Tomography (Figure CT_scan) of the MATROSHKA phantom can be converted into a 3-dimensional voxel phantom with the help of external software. The same geometry, material, density and distribution of the real phantom has to be used in the Monte Carlo model for the simulation of the radiation distribution inside the phantom (figure numerical_model). The imparted energy and dose at the surface and in specified locations inside the phantom will be determined for special reference radiation conditions. The information gathered will be used in MATSIM-Phase B, for the validation of the numerical modelling of the dose distribution by measurements in photon and neutron fields.

Further investigations considering the complex radiation field onboard the ISS will allow the simulation of the dose distribution in the phantom under space radiation conditions. MATSIM will provide comprehensive risk assessment of radiation hazard to humans in space due to ionising and high energy particle radiation supporting the next project phase of the MATROSHKA experiment. This project will therefore provide a detailed knowledge of the radiation environment at the ISS which is needed to assess radiation hazards to humans as well as to electronic devices, sensors and equipment.

Infobox

Project duration:

01.07.2007 – 30.06.2008

Coordinator:

Austrian Research Centers GmbH – ARC
Radiation Safety and Applications Division
Department Radiation Safety Research
A-2444 Seibersdorf, Austria
www.radiation-seibersdorf.at
Dr. Peter Beck, Mail: peter.beck@arcs.ac.at
Dr. Sofia Rollet, Mail: sofia.rollet@arcs.ac.at

International Partners:

Vienna University of Technology
Atomic Institute of the Austrian Universities
Radiology, Radiation Protection and Nuclear Measurement
A-1020 Vienna, Stadionallee 2, Austria
www.ati.ac.at
Univ.- Prof. Norbert Vana, Mail: vana@ati.ac.at
Univ.- Ass. Michael Hajek, Mail: mhajek@ati.ac.at

German Aerospace Center - DLR, Institute of Aerospace
Medicine, Department for Radiation Biology
51147 Cologne, Germany
www.dlr.de/me/
Dr. Günther Reitz, Mail: guenther.reitz@dlr.de
Dr. Thomas Berger, Mail: thomas.berger@dlr.de

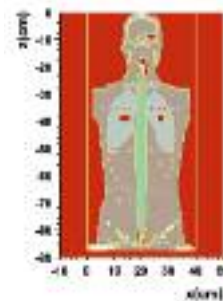

METTRANS

Metastable Solidification of Composites: Novel Peritectic Structures – Studies with Transparent Model Alloys

Transparent model systems of peritectics are quite attractive for furthering our understanding of solidification of metastable in situ composites. Such systems offer the advantage that both the morphology and the dynamics of solidification can be investigated by using optical diagnostic means. The comparison of experiments both on Earth and in Space gives access to determine directly the effect of gravitational phenomena as natural convection on the growth morphology and dynamics of peritectic solidification. In cooperation with the ESA-MAP project METCOMP, the present project is intended to directly observe morphological changes of the solid/liquid interface for the transparent metal-like solidifying peritectic model system Neopentylglycol – Tris(hydroxyl-methyl)aminoethan. It is planned to perform systematic studies of the peritectic solidification phenomena, which occur at the limit of constitutional undercooling around the peritectic point. As known in literature, a number of different morphologies are possible: oscillatory morphologies (bands), coupled growth (lamellar, island), etc. So far our observations indicate an unexpected unsteady seaweed-like morphology which is highly dependent on time. As all these morphologies are strongly influenced by the presence of convection, it is planned to perform experimental investigations under reduced gravity conditions using the DIRSOL facility on board the International Space Station/ISS in 2008.

METTRANS is a complementary project that will assist the ESA-MAP project METCOMP to further study the technical requirements that have to be fulfilled, in order to perform micro gravity experiments in the DIRSOL facility of the Microgravity Science Laboratory, MSL, located in the European Columbus Model on board the ISS.

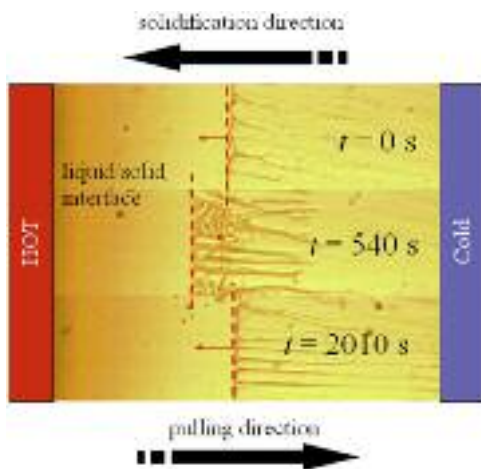

Infobox

Project duration:

01.03.2007 – 31.12.2008

Coordinator:

Univ. Prof. Dr. rer.nat. Dipl. Phys. habil. Andreas LUDWIG
Chair for Simulation and Modelling of Metallurgical
Processes, Department of Metallurgy
University of Leoben
A - 8700 Leoben, Franz-Josef-Str.18
Mail: ludwig@unileoben.ac.at

Partners:

All members of the associated
ESA-MAP Project METCOMP
Dr. Matthias Kolbe, German Aerospace Center, DLR, D
Prof. Dr. G. Eggeler, Ruhr-University Bochum, D
Prof. Dr. László Gránásy, Brunel University (RISSPO), UK
Prof. Dr. Dieter M. Herlach, German Aerospace Center,
DLR, D
Prof. Dr. Michel Rappaz, EPFL Lausanne, CH
Dr. René Duursma, Corus Technology BV, NL
Dr.-Ing. Jürgen Jestrabek, Schwermetall Halbzeug-Werk
GmbH&Co.KG, D
Dr. Claudio Penna, Swissmetal SA, CH
Dr. Jürgen Stahl, Thyssen Krupp Steel AG, D
Dr.-Ing. Hans-Achim Kuhn, Wieland-Werke AG, D



SERMER

Sensors for the Remote Monitoring of Experimental Reactors

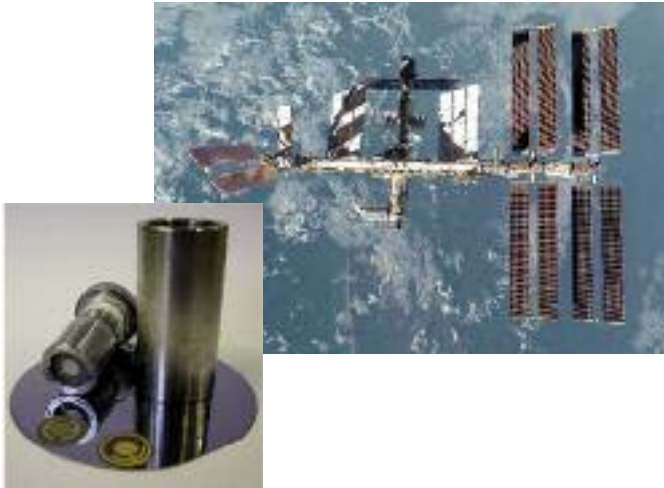

The monitoring of experiments conducted on the International Space Station (ISS) requires the utilization of novel miniaturized sensors. By considering a pilot application, i.e. the synthesis of zeolite-structures under microgravity conditions, which has been investigated by an associated ESA consortium, a novel system enabling the monitoring of reactions in the liquid phase is devised and investigated. Zeolites play an important technical role in sustainable industrial development. The structuring of zeolites involves self-organization processes within so-called Ordered Liquid Phases (OLPs) of nanoscopic precursor species. It was found that microgravity strongly favours the ordering and aggregation processes within the OLPs. Microgravity conditions thus offer a unique environment where these effects can be studied in detail. The planned microgravity experiments are essential to gain information on the rheological parameters affecting the formation of zeolites. The ambition of the team of European scientists in the ESA-consortium is to generate the fundamental knowledge that will ultimately enable design and synthesis of 'Zeolites on Demand' with the confidence of handling OLPs at will.

In the frame of the associated ASAP-project SERMER, miniaturized viscosity sensors enabling the monitoring of the zeolite synthesis process are considered in particular. The investigated sensors need to be capable of reliably monitoring crystallization processes involving nano-particles. Thus the suitability of the devices with respect to rheological measurements of complex liquids is a major issue in this research. Furthermore,

the technology needs to be developed such that it can withstand the harsh environment present (including extreme pH-values such that triple containment of the experimental reactor is required). In sum, the R&D activities within SERMER deal with the hardware of the viscosity sensor prototype, the readout, and the interpretation of the sensor signals with respect to the ongoing processes within the experiment to be monitored.

The results from SERMER will be applicable beyond the pilot application for further experiments aboard the ISS and for several industrial applications (such as in online process control).

Infobox

Project duration:

1.1.2007 – 31.12.2008:

Coordinator:

Univ.Prof. Dr. Bernhard Jakoby,
Institute for Microelectronics and Microsensors,
Johannes Kepler University Linz, Altenberger Strasse 69,
A-4040 Linz, www.ime.jku.at,
bernhard.jakoby@jku.at, +43 732 2468 9300

Major Partners:

Centre for Surface Chemistry and Catalysis
Catholic University of Leuven (KU Leuven)
www.biw.kuleuven.be/cok/
Prof. Dr. Christine Kirschhock

Institute for Sensor and Actuator Systems
Vienna University of Technology
www.isas.tuwien.ac.at
Prof. Dr. Michiel Vellekoop

Department of Chemical Engineering
Catholic University of Leuven (KU Leuven)
<http://cit.kuleuven.be/>
Prof. Dr. Jan Vermant



Launcher

FLEX

FLEX

Flexibles and Expansion Joints

Liquid rocket engines usually have the possibility of gimbaling. Several lines are needed to supply the engine (picture 1). Typical lines are feed lines, pressurisation lines, purge lines. Flexibility of these lines is necessary, so that they can accommodate deflections imposed by the engine (additional to vibrations, temperature, pressure...) and cryogenic fluid media (LH₂... liquid hydrogen, LO_x... liquid oxygen and others).



Therefore engine lines are the most complex lines and have limited life time due to big deflections. The lines may have diameters between 6 and 200 mm. Future propulsion systems will operate at higher pressures compared to actual ones (currently 5 to 10 bar). Therefore flexible lines need to become more sophisticated requiring advanced development techniques.

During the work following aspects have been worked out:

- requirements for flexible elements from general stage routing considerations have been derived
- different designs of expansion joints and flexibles (advantages and disadvantages) have been analysed
- knowledge about the behaviour of expansion joints and flexible hoses and their life time has been increased (picture 2).
- The methods to predict the life time of expansion joints and flexible hoses have been analysed and new methods for life time and behaviour prediction of flexible hoses have been shown

This study was not only limited to cryogenic feed lines for launchers, but evidently focussed on cryogenic fluids as for future launchers (NGL). Furthermore, this study also includes data of American and Asian stages.

Infobox

Project duration:

01.04.2006 – 28.02.2008

Coordinator:

Magna Steyr Fahrzeugtechnik AG & Co KG

Division Space Technology

DI Kurt Irnberger

A-8041 Graz, Liebenauer Hauptstrasse 317

www.magnasteyr.com

mail: kurt.irnberger@magnasteyr.com

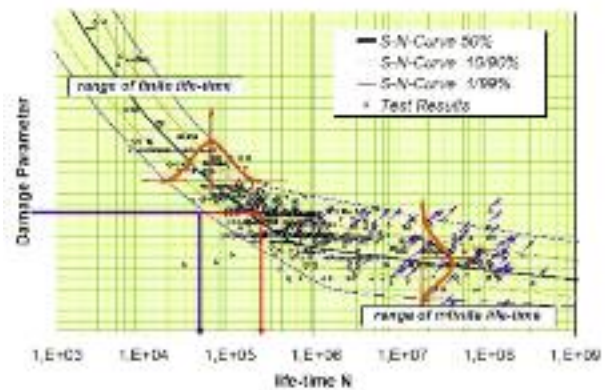

Navigation

AUSPRO

BALANCE

DIGSTER Go & Map

eGame

GALIMET

GNSS-MET

ODILIA

POMAR 3D

PPos-Taxi

SANOWA

SKISPRUNG

SPEF

SVEQ

AUSPRO

Austrian GNSS Service Provider

The Road Map describing the set up of the European Satellite Navigations System GALILEO offers besides the so-called SIS (Signal in Space) Services also room for regional augmentations (Regional Service Providers (RSP)). Today regional augmentations are most likely based on data of active GPS or GPS+GLONASS reference networks with a mean station distance of about 70 km. They usually offer customers Code-Range und Phase-Range correction data to allow sub-meter positioning down to precise positioning with cm accuracy in real-time. Even today these RSPs are in competition with a growing number of organisations and services offering GNSS corrections globally (eg. IGS, JPL,...) or on an continental scale (WAAS, EGNOS, MSAS,...) via geostationary satellites or via the Internet. In future, when also GALILEO becomes operational in 2012 or 2013, Navigation Satellite Systems offer the user community about 85 active satellites in Medium Earth Orbits which might allow for positioning accuracy of a couple of decimetres based on SIS Services without regional or local augmentations.

The questions raised in this project aim at ensuring technical and business opportunities of Austrian GNSS Service Providers. We are planning to investigate in detail

- the economic opportunities of Austrian Service Providers based on improved service levels compared to SBAS Services.
- the future potential of high-precision geodetic applications, both static and kinematic ones such as the inspection of railway tracks and the online control of construction equipment, compared to applications sufficiently covered by SBAS augmentation Services.
- the future optimum network geometry both from a technical and economic point of view (mean stations distance, ties to international coordinate frames,...) and the increased demands on correction data based on a variety of signals offered by receiver manufacturers especially with the start of the European Satellite navigation system GALILEO.
- the future potential and user needs in positioning accuracy of geophysical and meteorological real-time monitoring systems (monitoring networks for disaster prevention, high frequency earthquake monitoring systems, tropospheric content of humidity for weather-forecasts,...)



Infobox

Project duration:

01.01.2008 – 31.12.2008

Coordinator:

Institute of Geodesy und Geophysics, TU Wien
Ao. Prof. Dr. Robert Weber

1040 Wien, Gußhausstrasse 27-29 / E128

Phone: +43 1 58801 12865

Email: rweber@mars.hg.tuwien.ac.at

<http://mars.hg.tuwien.ac.at/>

Partners:

HiTec – Vereinigung High Tech Marketing

1030 Wien, Lothringerstraße 14/6

www.hitec.at

Dr. Susanne Fuchs

Wienstrom GmbH – Geschäftsfeld Netz

Referat Digitales Grundplanwerk

1095 Wien, Mariannengasse 4-6

www.wienstrom.at

Dipl.Ing. Christian Klug

ÖBB Infrastruktur Bau AG T-Kom Services

1100 Wien, Laxenburgerstrasse 4,

Dipl.Ing. Manfred Stättner

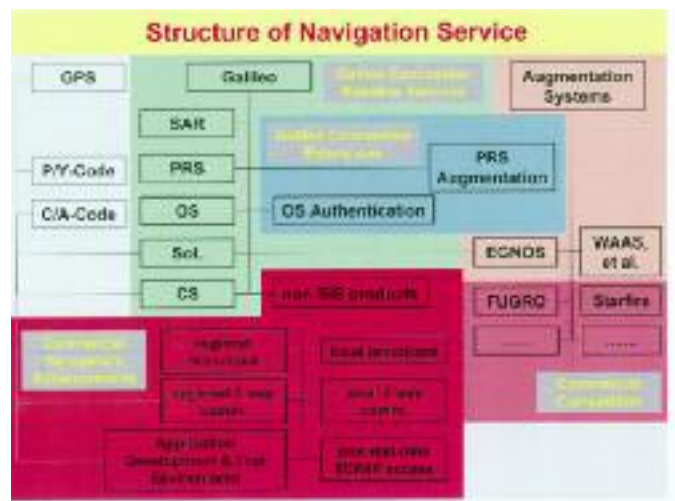

BALANCE

Sustainable Management and Information System for National Park Visitors and National Park Operators

Nature conservation areas such as national parks or biosphere parks and their visitors need information about each other in order to offer, plan and enjoy visits, while at the same time protecting nature. Therefore the BALANCE project follows a two-tier strategy: on the one hand an easy-to-use GPS/GALILEO suitable mobile guide is being developed, which offers location and time based information to the visitors while at the same time tracking their routes. On the other hand, this tracking information is anonymously transferred to the analysis and prediction tool developed in BALANCE, which delivers easy to use information for the national parks about their visitors' behaviour (e.g. favourite routes, stops, etc.). At the same time it offers routes according to the visitors' preferences, e.g. sending them to areas, which still offer the spots (flowers, animals) they want to see most. The three research partners combine their knowledge in GPS/GALILEO based mobile guide development, visualisation, development of analysis and prediction models and sustainable recreation planning while two National Parks do not only offer different test sites for BALANCE, but also bring their expert view on typical visitors' requests as well as national park operator requirements specification for the analysis and prediction tool to bear in the project.

The complete BALANCE system, which can only work due to the information delivered by GPS/GALILEO tracking technology, will benefit all stakeholders in the sustainable tourism sector alike: National parks are enabled to develop new offers for their visitors while at the same time protecting sensible or overly crowded areas, and potential visitors can easily plan their visits ahead and receive trip information according to current developments in the park.



Infobox

Project duration:

1.5. 2007 – 31.10.2008

Coordinator:

arsenal research

Österreichisches Forschungs- und
Prüfzentrum Arsenal Ges.m.b.H.

DI Helmut Schrom-Feiertag

A-1210 Wien, Giefinggasse 2

Phone: +43 (0) 50550-6659

Mail: helmut.schrom@arsenal.ac.at

Partners:

Joanneum Research

Institute of Digital Image Processing

DI Alexander Almer

www.joanneum.at

University of Natural Resources and Applied Life Sciences

Institute of Landscape Development, Recreation and
Conservation Planning

Ao.Univ.Prof. DI Dr. Andreas Muhar

ifl.boku.ac.at

MA 49 Forstamt und Landwirtschaftsbetrieb

der Stadt Wien

DI Herbert Weidinger

www.wien.gv.at/wald/

Nationalpark Thayatal GmbH

Dir. DI Robert Brunner

www.np-thayatal.at

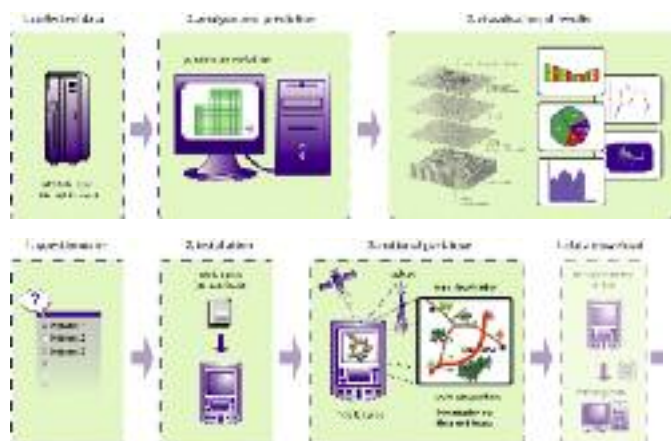

DIGSTER Go & Map

DIGSTER – Digital Satellite Based Terrain Mapping: User Requirements

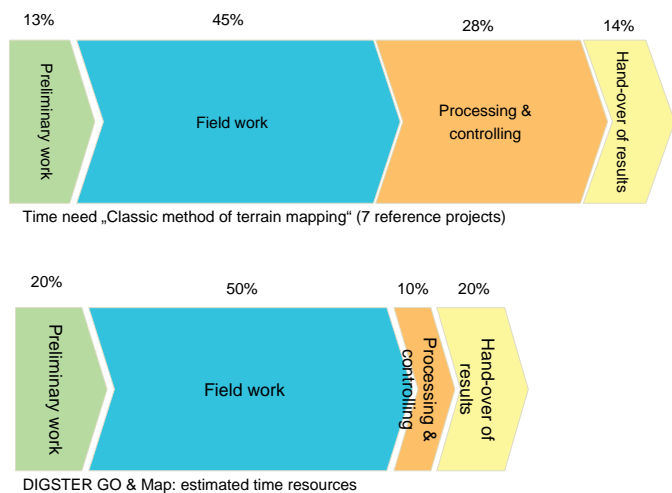

The project DIGSTER – Go & Map (Digital Satellite Based Terrain Mapping) aims at meeting user requirements of the technical aspects of digital terrain mapping. For many questions in administration, planning and expertise, terrain mappings are indispensable. During terrain mapping campaigns experts gather information in the field systematically and in a further step transfer the information into computer aided systems for processing, analysing and visualization purposes.

The results of the project DIGSTER – Go & Map establish the basis of digital terrain mapping by developing the components and putting them together to a complete system. In this phase the project has concentrated on the user requirements of digital terrain mapping. The whole process from data acquisition in the field up to the accomplished map products will be digitally performed by the system. Therefore, a platform appropriate for the use in the field (Personal Digital Assistant or Tablet PC) has been combined with technologies from the disciplines of satellite navigation, remote sensing, communication, and mobile geoinformation systems. To support the field mapping process, a base vegetation map (scale 1:25.000) as background for field mapping has been developed. This vegetation map is built up by the combination of existing datasets in raster- and vector-format (e.g. satellite images, orthofotos, older vegetation- and landuse-datasets). This dataset offers the following advantages: on the one hand it speeds up the field work and on the other hand it provides a dataset of the whole area with a homogenous data-quality.

Based on that, the technical components for a digital terrain mapping system will be developed and integrated to the level of a "demonstrator" (preliminary study).

Infobox

Project duration:

21.02.2007 – 30.04.2008

Coordinator:

E.C.O. Institut für Ökologie, Hanns Kirchmeir

www.e-c-o.at

9020 Klagenfurt, Kinoplatz 6

Phone : +43-463-504144

Fax : +43-463-504144-4

Mail: kirchmeir@e-c-o.at

Partners:

University of Technology Graz,

Institute of Remote Sensing and Photogrammetry

www.geoimaging.tugraz.at

Mathias Schardt

University of Technology Graz, Institute of Geoinformatics

www.geoinformation.tugraz.at

Norbert Bartelme

JOANNEUM RESEARCH Graz, Austria

www.joanneum.at

Bernhard Pelzl and Edmund Müller

TeleConsult Austria GmbH, Graz, Austria

www.teleconsult-austria.at

Bernhard Hofmann-Wellenhof

Stand Montafon, Schruns, Austria

www.stand-montafon.at

Bernhard Maier



The current feasibility study can be seen as the first phase of a three phase interdisciplinary project called "Development of an integrated telemetry system for game management in matters of traffic security, protection forest and private forest based on navigation, communication, remote sensing, and GIS methods".

Current wildlife telemetry systems by means of bearing transmitters unfavorably disturb the animal's behaviour and are time consuming. Newly developed systems based on GPS and GSM technology actually have a relatively low data rate due to a restricted energy supply. Therefore, a telemetry system based on GPS and GSM technology has been developed which allows a generally higher data rate due to additional energy generation while the system is fixed on the animal. Furthermore, it enables the flexible adjustment of the data rate to external conditions such as weather and actual whereabouts of the animal. A camera mounted on the telemetry collar provides additional significant information on the animal's behaviour.

The present feasibility study was designed to clarify whether the proposed design of a long-term data acquisition system for the remote monitoring of game is practicable. It focused on specifying the user requirements, solutions for critical technical components, and basic testing of system components. Special respect was given to the sufficient energy supply for the whole system as well as mechanical requirements. In a three-week field test the technical components and the collar material were investigated concerning their robustness.



Infobox

Project duration:

01.04.2007 – 30.11.2007

Coordinator:

JOANNEUM RESEARCH

Institute of Digital Image Processing

8010 Graz, Wastiangasse 6

Univ.-Prof.Dipl.-Forstw.Dr. Mathias Schardt

Phone: +43 (316) 876/1754

Fax: +43 (316) 876/1720

Mail: mathias.schardt@joanneum.at

www.joanneum.at

Partner:

Wildökologische Waldwirtschaftliche

Naturräumliche Planung & Beratung

Dipl. Ing. Martin Forstner

With the proposed design of the device a solution which is stable, yet flexible and adaptable to the size of the animal, has been found. The use of flexible solar cells will be the key point for the durability of the system over the lifetime which is expected to be longer than one year. An energy balance has been calculated for an optimal system profile – a design which represents the currently known user requirements in the best possible way without compromises. It resulted in a sufficient energy supply for the whole system. Innovative aspects, like power supply by solar panels and fuzzy or interactive adjusting of the system, present a major improvement to common telemetry systems and thus meet the requirements of the users.



GALIMET

Application of Satellite-based Location Services for Warnings against Hazardous Weather

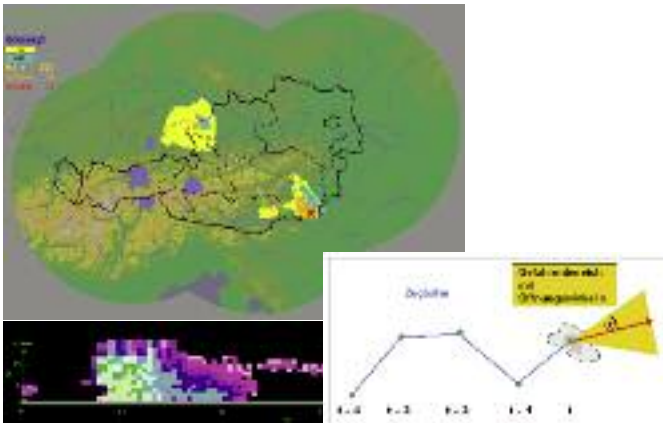

The GaliMet project is a satellite based system, which generates warnings transmitted by mobile phones to the users in case of severe weather. Warnings are given in case of heavy precipitation, thunderstorms or hail occurring in the near neighbourhood with a high probability of affecting the user in the next 1 or 2 hours. The addressed people will then have the possibility to seek shelter or to take any other action to prevent further damages. The target group for this kind of warnings is anyone doing some kind of outdoor activity, hail warnings specially address drivers.

In case of strong convective storms, a major problem arises: how to get the most accurate information concerning intensity of thunderstorms and areas most likely affected. At present information about thunderstorms is given for a wide area in space and time in the general weather report. Year after year, tourists, hikers, mountaineers, sailors, and surfers are affected by unexpected severe weather conditions leading to injuries or death. The usual weather forecast is standardised, not always available and often with a time lag.

Every year hailstorms cause property losses exceeding millions of Euros. A warning in good time could help drivers to seek shelter, thus avoiding damage to their cars.

The combination of the user's position and high resolution weather data from radar and satellite images could not only increase the accuracy of a warning but also reach people who are in danger.

The aim of the project is to create an operational prototype of a satellite based warning system and to conduct a successful test phase with a limited number of users. For the implementation, four tasks will be defined:

- The satellite based determination of the position of the user
- The recognition and tracking of severe convective storms
- The development of an automatic warning tool and easy-to-use products for the mobile phone
- The immediate transmission of the warnings to the target group: outdoor activists, drivers.

The outcome of the project is an increased accuracy in locating users with a satellite based system, an increased accuracy in time and space in determining the affected areas by thunderstorms, leading to a faster and more specific warning of the endangered people. The development of a fully automatic warning tool aims at convincing the test group of the usefulness of the warnings given. Finally, a business model for the mobile warning system will be elaborated, as well as a cost/benefit analysis for the motor vehicle insurance sector.

Infobox

Project duration:

12 month

Coordinator/Lead:

MOWIS GmbH – MOBILE WORLD INFORMATION SYSTEMS

A-4860 Lenzing, Max-Winterstrasse 28,

Tel. +43 7672 94700-0, Fax. +43 7672 94700-20,

Mail: r.steps@mowis.com, Web: www.mowis.com

Partners:

Zentralanstalt für Meteorologie und Geodynamik
A-1190 Wien, Hohe Warte 38

Hutchison 3G Austria GmbH

A-1110 Wien, Guglgasse 12, Stiege 10, 3.Stock



GNSS-MET

Rapid Delivery of Tropospheric Wet Delays Based on GNSS Observations for Weather Forecast

The importance of high resolution meteorological analysis of the mountain atmosphere has increased in recent years due to local and regional extreme precipitation. A detailed analysis of the humidity field is an important precondition for better monitoring and better forecasting of these events. For this reason, ZAMG has operated the spatial and temporal high resolution INCA system (INCA = Integrated Nowcasting through Comprehensive Analysis) since the beginning of 2005. Errors in this analysis occur mainly in alpine areas where the predicted models do not reproduce the atmosphere correctly.

The aim of the project is to provide GNSS based measurements of the tropospheric water vapour content to be used within the INCA system. We obtain GNSS reference station data from the network KELSAT (operated by the KELAG company) covering the mountainous area of Carinthia. KELSAT represents one of the still very rare networks observing both GPS+GLONASS satellites and therefore offers an almost unique environment for this project.

When GNSS (GPS, GLONASS, in future GALILEO) satellite microwave signals are transmitted through the atmosphere, they are affected by the media. One of those components is the tropospheric refraction. The tropospheric time delay can be split up into the hydrostatic part, calculated from pressure and temperature measurements at the observing station, and into a wet component, describing the rapid variable water vapour content of the troposphere. To separate the hydrostatic part from the wet contribution we use ground measurements from nearby located Meteorological Sensor Stations (TAWES network). The remaining Wet Delay (ZWD) may be converted into Integrated Water Vapour (IWW) if the temperature at the GNSS Sensor Station is available, too. In sum, the GNSS based ZWD is an integral value, but available with high temporal resolution and horizontal resolution.

To contribute to operational numerical weather prediction the water vapour content has to be made available within 45-60 minutes. The Water Vapour estimates are forwarded to ZAMG to investigate and validate their potential and usefulness for operational weather forecasting.

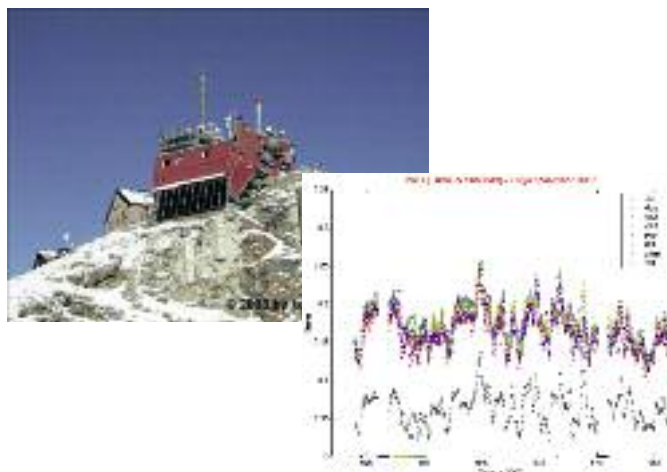
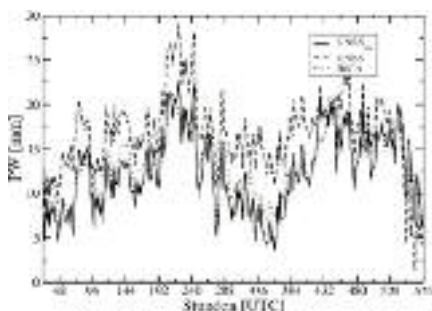

Infobox

Project duration:

01.09.2006 – 29.02.2008

Coordinator:

University of Technology Vienna,
Institute of Geodesy and Geophysics
Ao. Prof. Dr. Robert Weber
1040 Wien, Gußhausstrasse 27-29 / E128,
Phone: +43 1 58801 12865
Email: rweber@mars.hg.tuwien.ac.at
<http://mars.hg.tuwien.ac.at/>

Partners:

Zentralanstalt für Meteorologie und Geodynamik-ZAMG
A-1190 Wien, Hohe Warte 38
Dr. Thomas Haiden
www.zamg.ac.at

KELAG-Kärntner Elektrizitäts-Aktiengesellschaft
A-9010 Klagenfurt, Arnulfplatz 2, Postfach 176
Dipl.Ing. Harald Felsberger
www.kelag.at

ODILIA

Mobility of Visually Impaired Pedestrians by User-Oriented Information and Satellite-Based Navigation



The aim of ODILIA is the development of a demonstrator navigation system for blind and visually impaired people. Regarding all system components, the system is tailored to the special user requirements.

Blind and visually impaired people enforce their claim on a navigation system which should enable them to reach a certain destination independently from any other assistance. These requirements concern the hard- and software and also the user interface which is specially adapted to the needs of the user. Apart from long battery life, small size, and low weight, it is important for the user that the system can be worn without attracting attention of everyone. The software provides an individual configuration according to the user's demands. In route planning, the user can choose between the shortest and the safest route and, additionally, can decide to use means of public transport. Guidance instructions are available offering a lot of details. The system facilitates the user to set the individual amount of the provided information. It generates instructions about turns, delivers information on points of interest, and gives hints on obstacles occurring, for example, when walking on the pavement. Furthermore, the user is guided while crossing a street, and he is advised against stairs and obstacles that could cause injuries.

In order to reliably support conventional travel aids, the accuracy of positioning as well as of the digital map has to be in the tactile range of the white cane. In case of positioning, this is achieved by the integration of GPS and a pedestrian navigation module which compensates GPS signal outages due to shadowing effects as occurring in urban areas.

The guidance instructions must be provided without disturbing the user's acoustic perception of the surrounding environment. Therefore, head phones are not a suitable tool. Instead of that, vibrating signal pads are combined with small loudspeakers. Another important feature is a pre-trip training mode which allows the user to become acquainted with possible routes in advance and which offers the comparison of different routes under virtual conditions. Supported by AFN and the Styrian Association of Blind and Visually Impaired People, the project ODILIA has attracted a lot of interest and has gained positive reactions by potential users.

Infobox

Project duration:

01.09.2006 – 31.12.2007

Coordinator:

Institute of Navigation and Satellite Geodesy, TU GRAZ
www.inas.tugraz.at

A-8010 Graz, Steyrergasse 30

Contact: Manfred Wieser

Mail: wieser@geomatics.tu-graz.ac.at

Partners:

AFN Spezialentwicklungen, Anton F. Neuber
www.afn.at

Styrian Association of Blind and Visually Impaired People
www.stmk-bsv.at

Mario Kowald



POMAR 3D

Positioning and Orientation Module for a Mobile Augmented Reality Client for Real Time 3D Visualization of Underground Infrastructure

Popularity of three-dimensional city models is increasing rapidly. The project POMAR 3D continues a project called VIDENTE, which addresses the visualization of "underground city infrastructure".

VIDENTE, which is a research project in the area of Augmented Reality (AR), describes a prototype for three-dimensional visualization of underground infrastructure in real time. The end user will carry a handheld AR-client, which is able to provide the user with additional graphical information like supply pipelines (e.g. gas, electricity, etc.) depending on their position and orientation. A major issue in this project determines the position and orientation of the mobile AR-client in real time. This is necessary to properly superimpose the additional three-dimensional features on the real scene.

In this context, the goal of POMAR 3D is the development of an integrated positioning and orientation module, which fits the high requirements of the VIDENTE AR-client. Integrating GNSS like GPS, EGNOS or GLONASS and a low-cost inertial measurement unit with the AR-client assures to accomplish the essential precision of position and orientation. Furthermore, high availability of the sensor data is of great interest. This is necessary to achieve a correct overlay of virtual underground infrastructure with the real world scenes. Additionally, the form factor of the AR-client plays a very important role as well. Therefore, besides delivering high precision data, the positioning and orientation module has to meet high demands regarding ergonomic issues of the setup, namely for size and weight.

When POMAR 3D started within the VIDENTE project, an efficient analysis of the necessary precision of position and orientation of the AR-client was performed. Having finished this step suitable hardware was acquired. This mainly consisted of a GNSS receiver and an inertial measurement unit. Parts of the module planned in POMAR 3D are implemented either in hardware or in software. After the system integration with the AR-client, the system is verified and tested under different conditions.

The main result of POMAR 3D is an integrated module for high precision measurement of position and orientation which is used within the AR-client. Furthermore, extensive evaluations with potential customers like utility companies, which have the need to manage their underground infrastructure, will be performed.



Infobox

Project duration:

01.09.2007 – 30.09.2008

Coordinator:

Graz University of Technology
Institute for Computer Graphics and Vision
www.icg.tugraz.at

A-8010 Graz, Inffeldgasse 16a/2nd floor

Dieter Schmalstieg

Mail: schmalstieg@icg.tugraz.at

Gerhard Schall

Mail: schall@icg.tugraz.at

Partner:

Graz University of Technology
Institute of Navigation and Satellite Geodesy
www.inas.tugraz.at

A-8010 Graz, Steyrergasse 30/III

Bernhard Hofmann-Wellenhof

Mail: hofmann-wellenhof@TUGraz.at

Norbert Kührtreiber

Mail: norbert.kuehtreiber@TUGraz.at

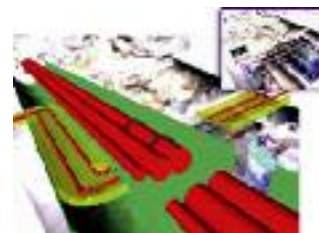

PPos-Taxi

Efficient Taxi Allocation Based on Precise Vehicle Positioning

The project PPos-Taxi represents an innovative contribution to an efficient allocation of taxis based on precise vehicle positioning. The booking office of the taxi company "Taxi 31300" uses GPS positions to automate the allocation of the taxis to the costumers. Due to the currently achieved positioning accuracy of about 10m-15m, it is impossible to identify the driving lane and direction especially in the inner city, on bridges and highways. This may result in waiting times not calculable for the customer.

The aim of the project is to provide the horizontal position of taxis within a few meters by means of two correction strategies (EGNOS and DGPS) and to test these strategies with regard to accuracy, availability, economic efficiency, and operator convenience. Contrary to similar approaches the correction data will be applied by software in the booking office and therefore do not have to be forwarded directly to the fleet of rovers.

The applied strategies are based on

1. using EGNOS-corrections via internet: In urban areas the EGNOS satellites are not visible due to obstructions by buildings, etc., so the raw GPS positions, sent to the central office by the taxis, must be corrected in the booking office in near real-time. Additionally, some taxis will directly try to receive EGNOS-corrections from the geostationary satellites to provide test data for a comparison of the availability and the accuracy reached.

2. using correction data of a permanent GPS-station (DGPS): Here the raw GPS position of the taxi is also corrected in the central office, using corrections of the WEP (Wienstrom Echtzeit Positionierung).

Additionally, the independent problem of multipath effects will be reduced by analysis of the signal-noise-ratio of the GPS-signals. The disturbed signal, which has a time delay due to reflections on buildings, trees, etc, can so be identified and removed, and the calculation of the position can be repeated.

After a successful realization of the project "Taxi 31300" has the opportunity to choose the most efficient service before upgrading the 800 vehicles in their fleet. The approach chosen can of course be used in general for fleet management in urban areas.

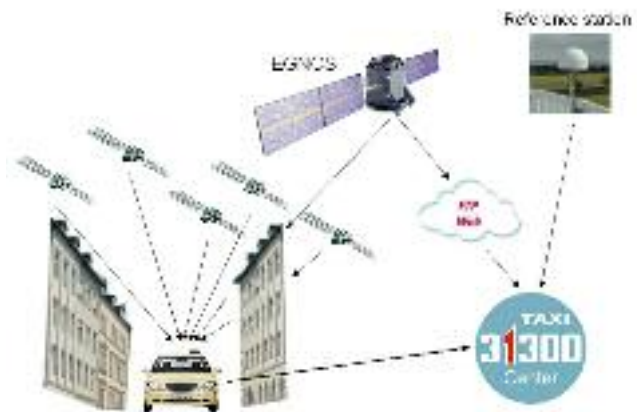

Infobox

Project duration:

1.2.2007 – 31.8.2008

Coordinator:

Institute of Geodesy and Geophysics
Vienna University of Technology

1040 Wien, Gusshausstrasse 27-29

Dr. Michaela Haberler-Weber

Tel.: 01/58801 – 12839

Michaela.Haberler-Weber@tuwien.ac.at

<http://info.tuwien.ac.at/ingeo/>

Partners:

Funktaxi 31300 VermittlungsgmbH & Co KG

www.taxi31300.at

Nikolaus Norman

Austrosoft® Weiss Datenverarbeitung Ges.m.b.H.

www.austrosoft.at

DI Michael Leitner

Wienstrom GmbH

www.wienstrom.at

DI Christian Klug



SANOWA

Satellite Based Emergency Call System for Lumberjacks

The objective of the project SANOWA (Satellite based emergency call system for lumberjacks) is the development of a demonstrator that will increase the safety of lumberjacks and facilitate rescue operations in case of an accident. Satellite navigation, autonomous sensors, wireless communication, and geoinformation systems are integrated in the demonstrator. A personal safety module carried by the lumberjacks will detect any motionlessness in case of an accident. The alarm will be forwarded wirelessly to a life-rucksack deposited in the immediate work area. The position of the rucksack is determined by integrating satellite navigation (GPS, EGNOS or Galileo), autonomous sensors, like electronic barometers, but also takes optional digital terrain models into account. The alarm message in combination with the position and further attributes is sent via a terrestrial GSM/GPRS network or a satellite communication link to the service centre.

The service centre receives the alarm message with the position of the person in distress, which is displayed on a digital map of the Geographic Information System (GIS). GIS facilitates identifying the closest team in the area, the shortest routes to approach the site, and the next medical and ambulance centre. GIS-based analysis assists in deciding whether to alarm the mountain rescue rather than the ambulance, or in finding the next helicopter landing places. Using all this information, the person in charge in the service centre gets a better idea of the situation and can initiate the most appropriate actions, again supported by the system. Optional, the alarm message may also

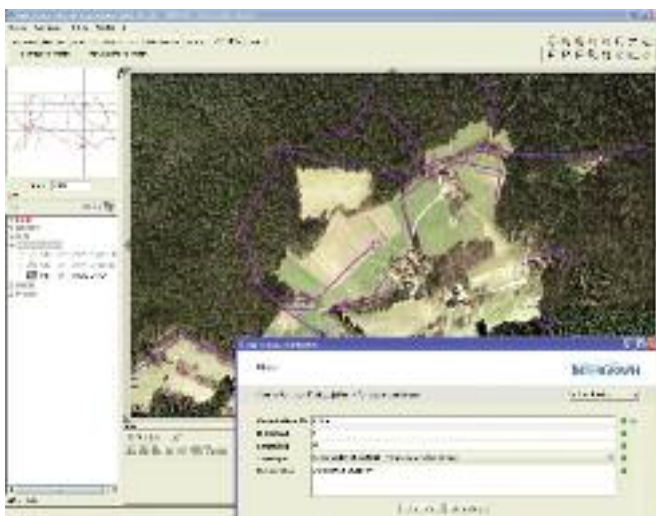

be forwarded directly to an emergency call centre like the main fire warden.

Alternatively, the men in the field might be alarmed through the system, if their life is at stake (i.e. thunderstorm warnings, forest fires). The service centre sends an alarm message to the life-rucksack in the area concerned, which then dispatches the information to the personal security modules of the lumberjacks if it is necessary. The risk of an accident will be reduced by this sequence of actions.

The system is modularly structured and designed to work for a lone worker as well as for a team of lumberjacks either in the manual wood work, in forest management or in cultural operations. The system may also be adapted to other applications like ambulances or fire fighters.

Infobox

Project duration:

1.12.2007 – 31.12.2008

Coordinator:

Intergraph Ges.m.b.H.

1050 Wien, Margaretenstraße 70/1/1

www.intergraph.at

info-austria@intergraph.com

Partners:

TeleConsult Austria GmbH

8043 Graz, Schwarzbauerweg 3

www.teleconsult-austria.at

Österreichische Bundesforste AG

3002 Purkersdorf, Pummergasse 10-12

www.oebf.at

Vereinigung High Tech Marketing

1030 Wien, Lothringerstraße 14/6

www.hitec.at



SKISPRUNG

Precise Trajectory and Velocity Determination in Ski Jumping



The most important indicators for the flight performance of a ski jumper are the flight trajectory itself and the corresponding velocity. Due to the fact that an accurate position and velocity information along the flight trajectory is available for coaches and athletes shortly after the jump, new and important analysis methods of the jump performance are made possible.

Therefore, the main objective of the project SKISPRUNG is the precise determination of these two indicators – the position and the velocity along the flight trajectory at each epoch. Furthermore, a demonstrator system for the immediate processing and analysis of the measured data should be provided. The system requires a position accuracy in the cm-level and a velocity accuracy of 0.5 km/h.

During the project, a “passive” and an “active” system are developed. The passive system consists of several high-frequency and high-resolution cameras which are able to track a label with an accuracy in the cm-level. The label is attached to the jumper’s dress according to the centre of mass of the jumper. Thus, the position and the height of trajectory points can be measured if the position and the orientation of the cameras are known. Since the recording is done with a high frame rate, the velocity can be determined and assigned to the corresponding trajectory points. The use of a passive system has the advantage that the athlete is not irritated by the measurement equipment and, therefore, the system can also be used during competitions. The active system uses GPS phase measurements in the relative-positioning mode. The receiver module is mounted between the

Infobox

Project duration:

01.12.2007 – 28.02.2009

Coordinator:

*Institute of Navigation und Satellite Geodesy
University of Technology Graz*

www.inas.tugraz.at

A-8010 Graz, Steyrergasse 30

Contact: Manfred Wieser

Mail: wieser@geomatics.tu-graz.ac.at

Partners:

Institute of Digital Image Processing

JOANNEUM RESEARCH

www.joanneum.at

Gerhard Paar

Institute of Sports Science

University of Innsbruck

www.sportwissenschafteninnsbruck.at

Werner Nachbauer

Österreichischer Skiverband

www.oesv.at

Werner Nachbauer

inner and outer shell of the helmet with the GPS antenna on top of the helmet. An important basic condition is the equipment’s weight. It should be less than 200 grams, since the equipment should not be a handicap for the ski jumper. A second GPS receiver is located at a reference point beside the ski-jumping platform. The jump trajectory is determined in post-processing mode.

On the one hand, the GPS data are used to provide the necessary verification of the passive system. On the other hand, the active GPS system is designed as a stand-alone application for training sessions. Its advantage is that it is easy to install. Thus, it can be easily used at different ski-jumping sites and is the proper tool to compare all the jumps of the athletes.



SPEF

Signal Processor Emulation Facility

Digital Signal Processing equipment on board of satellites usually comprises micro – or signal processors as well as associated Application Specific Integrated Circuits (ASICs). The design of such embedded digital signal processing systems is made complicated by the fact that ASICs have long manufacturing lead times. During this period engineering work concerning the whole system and in particular the development of software could be interrupted for several months.

The present emulation facility allows for efficient testing of the software running on a micro-processor that controls the ASIC while the ASIC is still being manufactured at the foundry.

With the availability of this facility delivery schedules of signal processing equipment can be significantly compressed, the efficiency of the entire development process can be increased and, thus, competitiveness of Austrian Aerospace in this product field is improved.

This tool is already being used during the development of the Galileo Signal Generator ASIC, a high-tech space qualified, radiation hard ASIC featuring more than 600 kGates. This ASIC generates the navigation signals of the Experimental Satellite (GIOVE-B, Figure 3) of the future European Galileo Navigation Satellite Constellation. The satellite is scheduled to be launched in 2008.

For the project described AAE has co-operated with Saab Space of Gothenburg who have contributed know-how regarding space borne micro-processor equipment.

Infobox

Project duration:

01.01.2006 – 18.01.2008

Coordinator:

Austrian Aerospace

www.space.at

Walter Hoermanseder

1120 Wien, Stachegasse 16

walter.hoermanseder@space.at

International Partners:

Saab Space

Gothenburg, Sweden

Markus Borsand

www.space.se

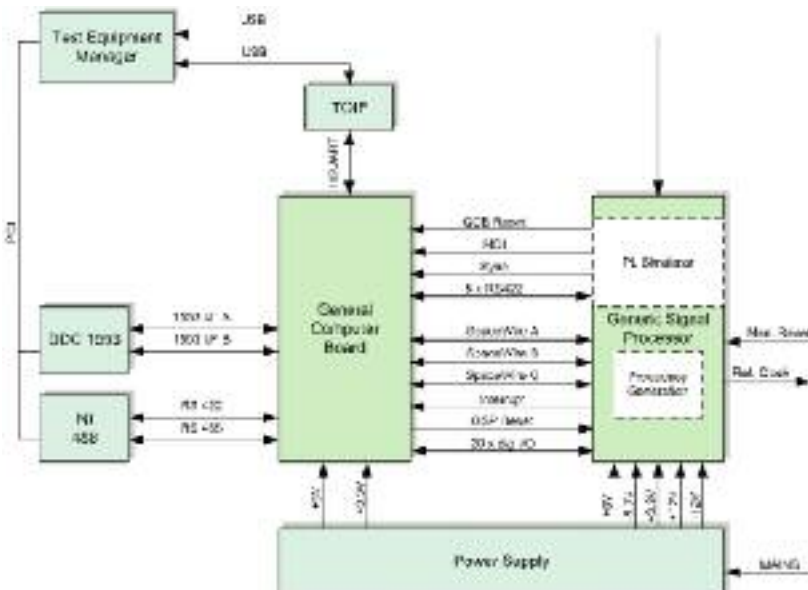

SVEQ

GNSS Receiver SW Verification & Qualification Framework



All elements of a spaceborne GNSS (Global Navigation Satellite System) receiver are ultimately united by the receiver software. Almost each and every hardware and/or system change will result in software modifications, in turn comprising design, implementation and test, as a consequence. The effort to test and qualify spaceborne software systems with these stringent requirements in terms of functionality, reliability and maintainability is normally in the range of 50% of the complete software development life-cycle.

The present activity aims at supporting inevitable product evolution by providing a framework for Software Verification and Qualification (VQ), implementing it in Austrian Aerospace's (AAE's) GNSS-receiver software and demonstrating its suitability by applying it to the transition from a receiver providing on-board spacecraft navigation functionality to a qualified scientific precise orbit determination instrument.

In the course of this study the receiver software architecture is optimized with respect to integrated qualification capabilities, and software qualification platforms are established facilitating verification/qualification of an evolutionary product software. The study is part of AAE's Product Development Program, aiming at the establishment of a product line of Spaceborne GNSS Receivers.

The activity is conducted in an international co-operation with Saab Space in Sweden, which provides essential test evaluation tools for the verification and qualification tests of GNSS receiver software.

Infobox

Project duration:

01.03.2007 – 30.09.2008

Coordinator:

Austrian Aerospace

Georg Grabmayr

1120 Wien, Stachegasse 16

Tel.: (1) 80199 5784

Mail: georg.grabmayr@space.at

www.space.at

International Partner:

Saab Space

Hans Fritz

Göteborg, Sweden

www.saabgroup.com

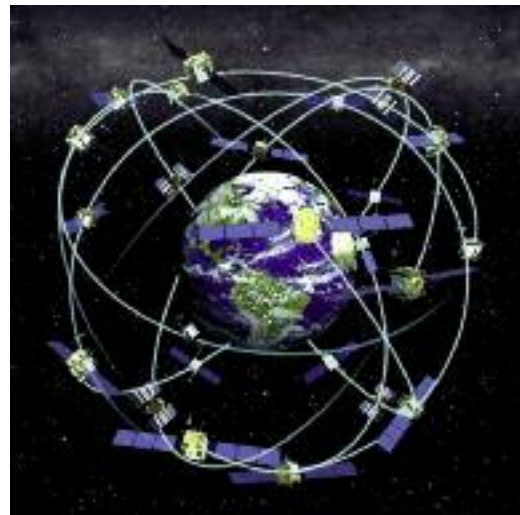

Space Science

BRITE-AUSTRIA

GEO_nAUT

INDIUM

MERMAG

PICAM

Resonance

TMIS.plus.II

BRITE-AUSTRIA

Development of the First Austrian Nanosatellite – Phase 1 & 2



The purpose of the BRITE-AUSTRIA / TUGSAT-1 project, funded by the Austrian Space Program, is the development of the first Austrian satellite. The scientific goal of this nanosatellite mission is the investigation of the brightness oscillations of massive luminous stars by differential photometry. The scientific instrument

is an optical camera with a high-resolution CCD to take images from distant stars with magnitude of 3.5. The spacecraft has a size of 20 x 20 x 20 cm and weighs 6.5 kg. It carries three computers: instrument processor, housekeeping and attitude control computer. 6-10 W of electrical power will be generated by solar cells. The telemetry operates in the science S-band for the downlink and in the UHF band for the uplink. In addition, a VHF beacon is provided. The data rate lies between 32 to 256 kbit/s and the normal daily downlink volume amounts to 2 Mbyte. The satellite makes use of recent advances in miniaturised attitude determination and control systems. Precision three-axis stabilisation by small reaction wheels and a star tracker guarantee a pointing accuracy down to arc minute level. This will provide the astronomers with photometric data of the most massive stars with unprecedented precision which cannot be obtained from the ground due to limitations imposed by the terrestrial atmosphere. The target orbit is polar or sun-synchronous with a height of 800 km. The Mission Control Centre is currently set up in Graz. Additional ground stations are operated in Toronto and Vienna.

Phase 1 of the project is concerned with the design, development and qualification testing of the spacecraft. Flight Readiness Review is planned for the end of 2008. The preliminary design was accepted in November 2006 and the specifications finalised in February 2008. Hardware construction and integration starts in April 2008.

Phase 2 deals with the investigation of launch opportunities and the development of the ground operations and science software. Launch is planned for the second quarter of 2009, depending on suitable piggy-back flights. The inter-disciplinary project is carried out by space experts at the various institutes with strong involvement of diploma and PhD students. A major goal is sustainability. TU Graz is planning to develop a generic satellite platform which can be used for future low-cost space missions, a project which receives interest from the scientific community and industry.



Infobox

Project duration:

Phase 1:

17.02.2006 – 31.12.2008 (ASAP III)

Phase 2:

01.09. 2007 – 30.4.2009 (ASAP IV)

Coordinator:

Institute of Communication Networks and Satellite Communications

Graz University of Technology

Prof. Otto Koudelka

A-8010 Graz, Inffeldgasse 12

Phone: +43 316 873-7441

Fax: +43 316 463697

Email: Koudelka@tugraz.at

Web : www.tugsat.at, www.iks.tugraz.at

Partners:

Institute of Astronomy, University of Vienna

Prof. Werner W. Weiss

www.brite-constellation.at

Institute of Communications and Radio Frequency Engineering, Vienna University of Technology

Prof. Arpad Scholtz

www.nt.tuwien.ac.at/research/radio-frequency-engineering/projects/

International Partner:

Space Flight Laboratory, University of Toronto, Canada

Dr. Rob Zee



GEOonAUT

The Austrian Geoid 2007

A new Austrian geoid model has been computed as a combined solution of local terrestrial gravity field observations (gravity anomalies, deflections of the vertical, "direct" geoid observations obtained by a difference between geometric heights derived from GPS observations, and orthometric heights derived from spirit levelling), and global gravity field information based on data of the satellite gravity mission GRACE. The terrestrial data are mainly sensitive to medium to high wavelengths. The incorporation of the global gravity field model, representing the long-wavelength information, results in a stabilization of the solution and a reduction of systematic effects such as biases and tilts.

The data bases of gravity anomalies, deflections of the vertical, and GPS/levelling information have been thoroughly validated, and new measurements of deflections of the vertical in the South-East of Austria have been performed. Additionally, a new digital terrain model (DTM) has been assembled as a combination of highly accurate regional DTMs of Austria and Switzerland, complemented by data of the Shuttle Radar Topography Mission (SRTM) in the neighbouring countries.

In addition to methodological developments of the standard technique of Least Squares Collocation (LSC), several alternative methods for the optimum combination of different (global and

local) data types, such as tailored series expansion (based on spherical harmonic base functions), multi-resolution analysis using spherical wavelets, fast multipoles techniques, and algebraic approximation methods have been investigated. For the final geoid solution, the LSC technique, representing the most mature approach, has been applied.

The new Austrian geoid solution, complemented by covariance information, has been thoroughly validated. The accuracy of this new solution can be estimated to be of the order of 2 to 3 cm. Thus, compared to the previous official Austrian geoid model, the accuracy and reliability was significantly improved. This is mainly due to the substantially improved quality of the input data, as well as several methodological developments performed in the frame of this project.



Infobox

Project duration:

01.04.2006 – 31.08.2007

Coordinator:

Roland Pail

Graz University of Technology

Institute of Navigation and Satellite Geodesy

A-8010 Graz, Steyrergasse 30

Tel.: ++43 316 873 6359

E-mail: pail@geomatics.tu-graz.ac.at

Web: www.inas.tugraz.at

Partners:

Graz University of Technology

Institute of Computational Mathematics, Olaf Steinbach

www.numerik.math.tu-graz.ac.at

Federal Office of Metrology and Surveying, Norbert

Höggerl, www.bev.gv.at

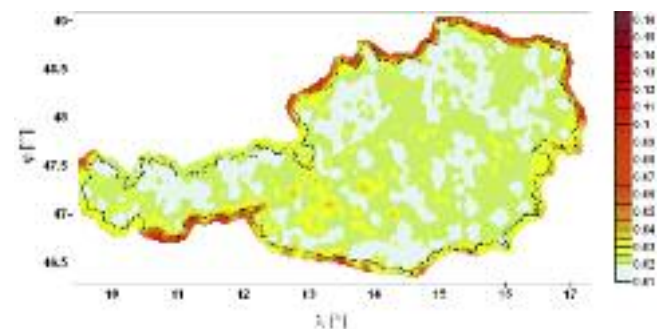
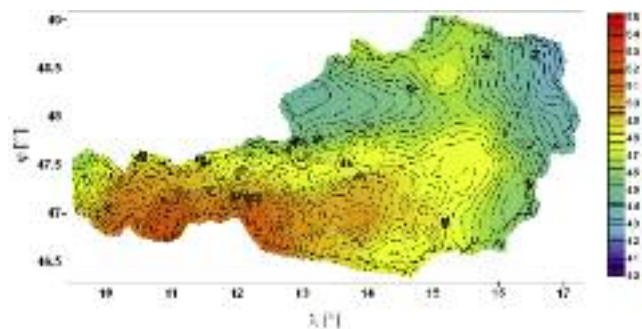
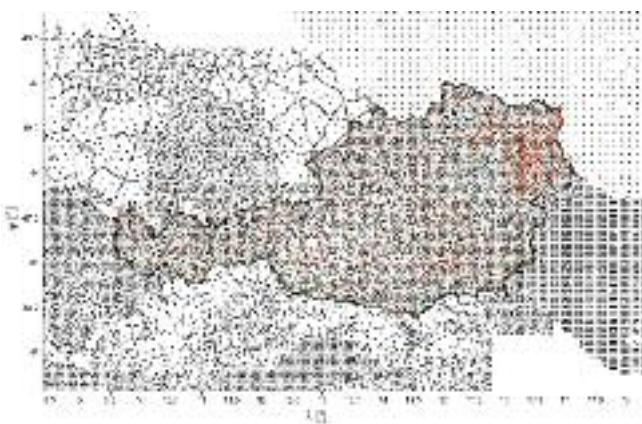

INDIUM

Storage Tests of Indium Ion Emitters

Developed more than 20 years ago, Indium Ion Emitters were first successfully tested on board the Russian MIR station in 1991 and have since flown on a number of satellites as part of a spacecraft potential control (ASPOC) or secondary ion mass spectrometer device. All missions in the past required the presence of a pyro spring cap to protect the Indium Ion Emitters from oxidation during long term storage. This pyro cap is both a risk element as well as a cost item.

For NASA's Magnetic Micro Scale (MMS) mission, a red cap option has been selected as the baseline design to avoid the spring cap method. In this design, a cap is attached on top of the module connected to a nitrogen supply to allow permanent purging. A similar method is to be used on LISA Pathfinder for the Indium FEED microthruster. Prior to launch, the red cap is removed.

This project aims at investigating whether the purging storage method is at least comparable to the previous spring cap method. We have to show by testing that the performance of the LMIS is not affected by prolonged purging.

For emitter sizes 0,5 g (MMS baseline) and 15 g (LISA PF baseline) three emitters were selected, documented for current / voltage characteristics, and put into a purging container. After 6 months of purging one 0.5 g and one 15 g emitter were taken out and tested again. If the emitters are firing they will be stored in standard atmosphere to simulate worst case exposure (as they have been from that day on) for another 6 months (e.g. in a dust-free box). A comparison between the nitrogen purged emitters with the one being exposed to the atmosphere is of specific interest. After one year (+/- one week) the remaining 4 emitters are being tested and documented, and the 2 modules stored under general ambient conditions are being tested again.



Infobox

Project duration:

01.08.2007 – 31.01.2009

Coordinator:

Austrian Research Centers GmbH – ARC
Space Propulsion & Advanced Concepts

Dr. Wolfgang Steiger
2444 Seibersdorf

Mail: wolfgang.steiger@arcs.ac.at

www.seibersdorf-research.at

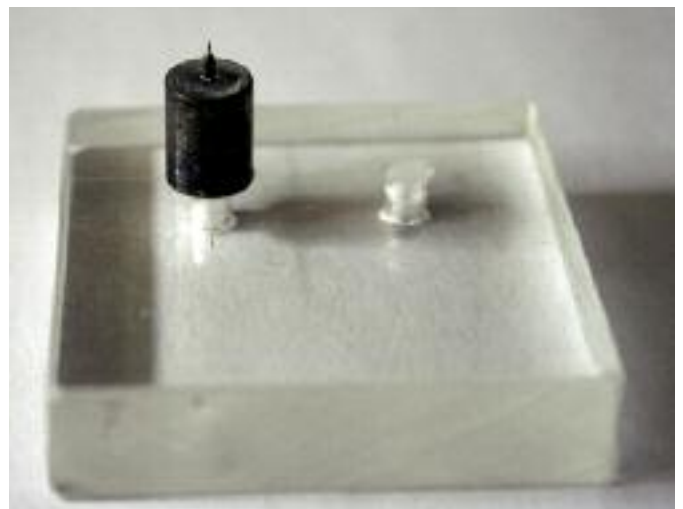
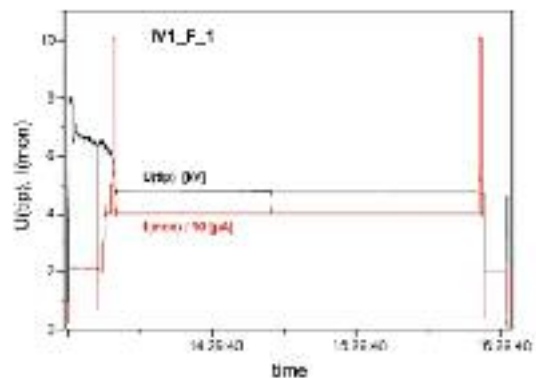

MERMAG

Mercury Magnetometers

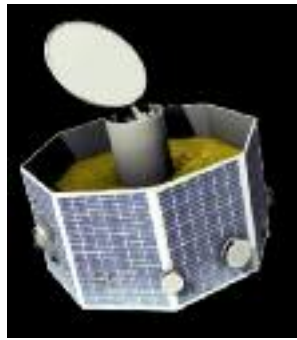
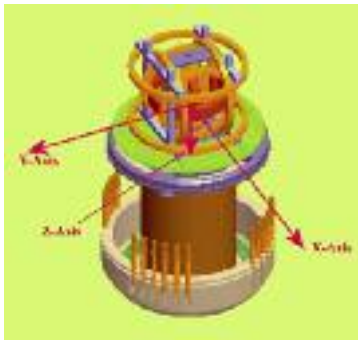

The satellite mission BepiColombo to Mercury, the planet closest to the Sun, is the first time that two spacecraft, the Japanese Magnetospheric (MMO) and the European Planetary Orbiter (MPO), will synchronously orbit around the innermost planet of our solar system. The BepiColombo composite spacecraft is setting off in August 2013 and is arriving at Mercury in August 2019. MMO and MPO will gather data during their one-year nominal mission from September 2019 until September 2020, with a possible one-year extension to 2021.

A European-Japanese consortium of scientific institutions has been formed to carry out the magnetic field investigations aboard both spacecraft. The coordinated studies will focus on the planetary magnetic field as well as its dynamic interaction with the young and strong solar wind in this region. The teams contributing to the magnetometer hardware are from ISAS Japan, TU Braunschweig, Imperial College London, and IWF Graz. IWF is the lead institution for the magnetometer aboard the Japanese MMO (MGF), while for the MPO magnetometer (MAG), IWF is responsible for the overall technical management.

Apart from the management activities, IWF is in charge of the instrument controller and on-board software development, instrument integration and calibration as well as the procurement of space-qualified integrated circuits. Both instrument designs are based on a digital fluxgate magnetometer which has been developed for magnetometers aboard the Rosetta/Lander, Venus Express, and Themis spacecraft. For the BepiColombo mission it is being modified so that it can cope with the harsh thermal environment around Mercury where sensor temperatures up to 180°C are expected.

Two contracts in the frame of ASAP 3 and 4 cover the preliminary and detailed design activities by IWF, which include hardware development for laboratory, engineering and qualification models of both magnetometers as well as the major portion of the parts

Infobox

Project Duration:

MERMAG ASAP 3: 01.02.2006 – 31.07.2007

MERMAG ASAP 4: 01.08.2007 – 31.01.2009

Coordinator / Project Lead:

Institut für Weltraumforschung (IWF)

Austrian Academy of Sciences

Prof. Dr. Wolfgang Baumjohann

Schmiedlstrasse 6, 8042 Graz

E-mail: baumjohann@oeaw.ac.at

www.iwf.oeaw.ac.at

Partners:

Institute of Space and Astronautical Science (ISAS)

Japan Aerospace Exploration Agency

Prof. Dr. Ayako Matsuoka

Institute of Geophysics and Extraterrestrial Physics

Technical University Braunschweig

Prof. Dr. Karl-Heinz Glassmeier

Space and Atmospheric Physics Group (SAPG)

Imperial College, London, Chris Carr



procurement. Financial support for the flight hardware development and the instrument integration and check-out activities before and immediately after launch is being supplied via ASAP 5.

The leading role of IWF in key-instruments (MERMAG and PICAM) of the ESA/JAXA BepiColombo cornerstone mission ensures the continued visibility of Austria at the forefront of international and interplanetary space research.

PICAM

Planetary Ion Camera

The ESA/JAXA mission BepiColombo to Mercury will be a milestone of solar system exploration. Mercury is very close to the Sun, a feature which makes in-situ observations very demanding from a technological perspective. An international consortium led by the Institut für Weltraumforschung of the Austrian Academy of Sciences has been selected by the European Space Agency ESA to provide a "Planetary Ion Camera" for the payload of the Mercury Planetary Orbiter to be launched in August 2013. The instrument PICAM is an ion mass spectrometer operating as an all-sky camera for charged particles to study the chain of processes by which neutrals are ejected from the soil, eventually ionised and transported through the environment of Mercury.

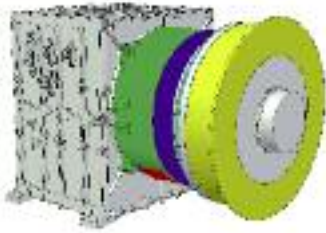

PICAM will provide the mass composition, energy and angular distribution of ions in the environment of Mercury. These observations will uniquely allow to study the low energy particles emitted from the surface of Mercury, their source regions, composition and ejection mechanisms, and to monitor the solar wind which may impinge on the surface and constitutes a major ejection process. This will allow better understanding of the formation of Mercury's tenuous atmosphere and the plasma within the cavity governed by its magnetic field.

The instrument PICAM combines high spatial resolution, simultaneous measurements in a full hemispheric field of view with a mass range extending up to ~132 atomic mass units (Xenon) and a mass resolution better than 1:50. The instrument consists of a sensor with the ion optics, the detector; and an electronics box. A special feature of the processing electronics is the on-board calculation of the ion mass spectra which is based on raw data obtained by random sampling of the incoming ions.

The PICAM Team is a consortium with major contributions from Austria, France, Germany, Belgium, Hungary, Russia, and Ireland. The Space Research Institute of the Austrian Academy of Sciences leads this investigation and provides the controller and data processing electronics as well as the on-board software: It is also responsible for integration and testing of the instrument against the adverse environmental conditions on Mercury, and participates in the calibration of the ion sensor which is crucial for the success of the mission.

Infobox

Project Duration:

PICAM ASAP 3: 01.02.2006 – 31.07.2007

PICAM ASAP 4: 01.08.2007 – 31.12.2008

Coordinator / Project Lead:

Institut für Weltraumforschung (IWF)

Austrian Academy of Sciences

Prof. Wolfgang Baumjohann

8042 Graz, Schmiedlstrasse 6

e-mail: baumjohann@oeaw.ac.at

www.iwf.oeaw.ac.at

Partners:

Space Research Institute (IKI), Russian Academy of Sciences, Dr. Oleg Vaisberg

Centre d'étude des Environnements Terrestre et Planétaires (CETP), Institut Pierre Simon Laplace
Dr. Jean-Jacques Berthelier

Max-Planck Institut für Sonnensystemforschung (MPS)
Dr. Joachim Woch

European Space and Technology Centre (ESTEC)
Dr. Philippe C. Escoubet

Research Institute for Particle and Nuclear Physics (KFKI)
Hungarian Academy of Sciences
Prof. Karoly Szegö

Space Technology Ireland, Ltd. (STIL)
Prof. Susan McKenna-Lawlor



Resonance

Electric Field Sensors

The analysis of the electric field sensors on board the satellites of the Russian mission Resonance, which will be launched in the next decade, is the focus of this project. The aim of this mission is the investigation of wave-particle interactions and plasma dynamics in the inner magnetosphere of Earth, with the focus on phenomena occurring along the same magnetic field line and within the very same flux tube of the Earth's magnetic field. Amongst a variety of instruments and probes, several low- and high frequency electric and magnetic sensors will be on-board.

In the course of this project the electric field sensors (antennas) are analysed with a focus on the high-frequency electric sensors. For that purpose two different methods are applied, an experimental and a numerical one. The former, called rheometry, is essentially an electrolytic tank measurement. The latter consists of the numerical solution of the underlying field equations by means of well-proven electromagnetic codes and computer programs written specifically for this purpose. A metallic scale model of the whole spacecraft including the antennas is built for rheometry.

This model has to contain all features of the spacecraft that influence the reception properties of the antennas. The numerical computer simulations are based on corresponding wire grid or patch models. While rheometry gives a reference with regard to modelling accuracy, the computer simulations facilitate the study of the sensor performance in dependence on sensor geometry modifications. So the most suitable configurations can be determined.

The project will provide information which is used for the decision on the final sensor configuration. In particular, the antenna capacitances and effective length vectors of different sensor options are measured and calculated for the quasi-static frequency range, yielding the sensitivity of the antennas to electric fields as a function of wave incidence and wave polarization. Furthermore, the accuracy of the evaluation and interpretation of the electric field observations which will be made on board Resonance will be improved by this detailed antenna analysis.

Infobox

Project duration:

1.11.2007 - 30.04.2009

Coordinator:

Space Research Institute (IWF)
Austrian Academy of Sciences
Department of Extraterrestrial Physics
8042 Graz, Schmiedlstr. 6
www.iwf.oeaw.ac.at

DI Dr. Wolfgang Macher
wolfgang.macher@oeaw.ac.at

Univ.-Prof. Mag. Dr. Helmut O. Rucker
rucker@oeaw.ac.at

Partners:

Prototypenbau Meister, pro.mei@aon.at
8042 Graz, Schmiedlstr. 8

Space Research Institute (IKI)
Russian Academy of Sciences
Moscow, Russia
Dr. Mikhail Mogilevsky
Dr. Mikhail Yanovsky

Laboratoire de Physique et Chimie de l'Environnement (LPCE)
Centre Nationale de la Recherche Scientifique
Orleans, France
Dr. Jean-Louis Rauch
Dr. Jean Gabriel Trotignon

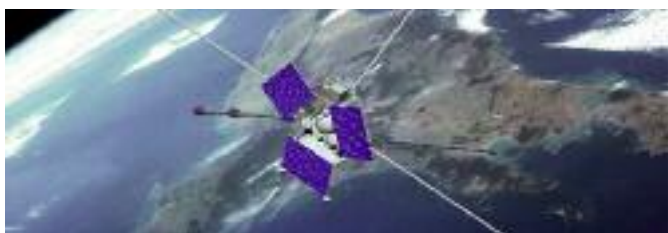

TMIS.plus.II

Maintenance and Extension of the Topographic Mars Information System (TMIS) and Processing and Analysis of Terrain Information from Mars Derived from HRSC Imagery

Data from the planet Mars captured by the camera HRSC (High Resolution Stereo Camera), on the European space probe Mars Express, are received and preprocessed at the German Aerospace Centre (DLR). The original data and derived data, such as digital terrain models (DTMs), are managed by TMIS, which provides a spatial catalogue for world-wide access. TMIS has recently been re-implemented and contains data covering some three quarters of the planet's surface. Besides maintaining the data catalogue, I.P.F. also uses the Mars DTM data for research activities in DTM analysis. In the course of the current project the focus is on areomorphologic analysis, in particular on generating highly informative visualisations.

Most techniques for surface presentation of DTMs do not reveal some areomorphic details that are important for interpretation in certain applications, e.g. for topographical mapping; for better understanding landform development, for improving areomorphic analysis, including detection and measurement of craters; for analysis and improvement of DTM quality; and others. Additionally, aspects of DTM generalisation and multi-scale presentation for visualisation have been considered. A combination of the proposed methods in various scales may improve recognizing and understanding features of landforms. Selected areas on the Mars have been tested using DTMs produced from HRSC images of the Mars Express mission and MOLA data from the US MGS mission.

The methods of areomorphic analysis that have been developed are: relative relief calculation (based on simulation of visibility), relative height coding (or "continuous" contour lines, based on modulo calculation), special edge enhancement. The latter produces a "worn out" impression (as known from hemlines of jeans) by using a combination of different techniques such as curvature calculation, various high-pass filtering, logical and arithmetical operations of variables for producing "relief-below", "relief-above", and "rim" indexes. Potential locations of the conical features (such as craters) can be marked by applying filters with an annular shape, resulting in annuli whose width indicates the radius and whose height (equivalent to a brightness offset in the visualisation) the depth of craters.

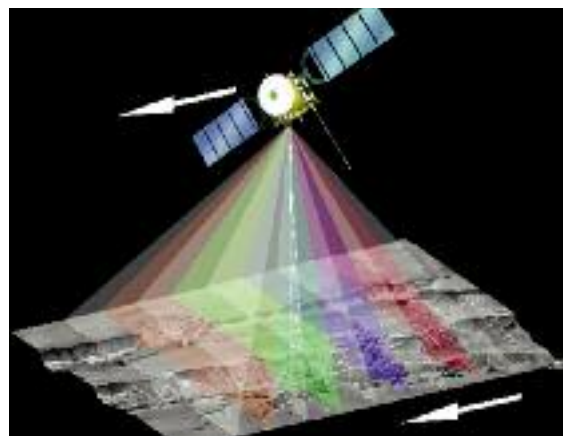

Infobox

Project duration:

October 2006 – March 2008

Coordinator:

Institute of Photogrammetry and Remote Sensing, I.P.F.
Vienna University of Technology, Josef Jansa
www.ipf.tuwien.ac.at

1040 Vienna, Gusshausstrasse 27-29 / 122,

Tel: +43 1 58801 12236

Fax: +43 1 58801 12299

Mail: jj@ipf.tuwien.ac.at

Partner:

Freie Universität Berlin

Prof. Gerhard Neukum (Principal Investigator)

www.geoinf.fu-berlin.de/projekte/mars/index.php

Deutsches Zentrum für Luft- und Raumfahrt

Berlin-Adlershof (Data Processing Group)

www.dlr.de/mars

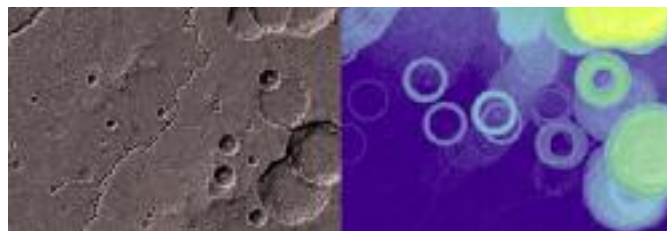

Space Technology

μPPT Development

GATE

LEO-SLR

SALOTTE

USI – Phase 1

VEDW

μPPT Development

Micro Pulsed Plasma Thruster Development for Micro- to Picosatellite Applications

Satellites of reduced mass continue to dominate near term flight manifests. Educational institutions throughout the world are currently developing picosatellites (satellites with a mass of less than 1 kg). The incorporation of active on board propulsion systems increases mission lifetime and the diversity of the missions which may be undertaken by small satellites. Therefore suitable propulsion systems must be developed which conform to the stringent mass and power requirements imposed by the miniaturisation of satellite systems.

ARC is currently developing Europe's first micro Pulsed Plasma Thruster (μPPT) with the ultimate objective of producing a flight model which may be flown on CubeSats. CubeSats are picosatellites with dimensions of 10 cm³ and hence impose the most demanding mass budget. To attempt to incorporate a propulsion system into a picosatellite is therefore a highly ambitious goal. However, the benefits of exploiting active on board propulsion as a mission enabling technology outweigh the increased system complexity and cost by far. The miniaturised PPT will also be suitable for micro and nanosatellite missions.

The μPPT is an ideal candidate for miniaturisation due to its structural simplicity. The use of solid propellant also forgoes the use of complex propellant feed systems. The μPPT also has the advantage of operating at low power levels compared to alternative electric thrusters. In the present study the main areas of investigation are the influence of electrode geometry on performance and the identification of appropriate circuit parameters in order to optimise μPPT operation. A performance with an impulse bit in the range of 10–30 μNs, specific impulse greater than 500 s, total impulse of 50 – 500 Ns and power of approximately 2 W is envisaged. These performance criteria will provide the capability to perform station keeping and attitude control tasks for a picosatellite as well as precision pointing to an accuracy of ± 1σ.

Further investigations will be performed on the electronics of the μPPT. The miniaturisation of the discharge initiation system and energy storage system are also critical to the viability of this technology for picosatellite applications.



Infobox

Project duration:

01.01.2006 – 13.07.2008

Coordinator:

Dr. Carsten Scharlemann

Austrian Research Centers GmbH – ARC

Space Propulsion & Advanced Concepts

A-2444 Seibersdorf

+43 (0) 50550 - 3143

carsten.scharlemann@arcs.ac.at

www.functional-materials.at

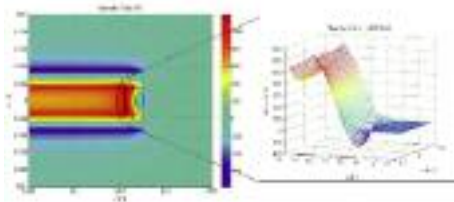

GATE

Generic ASIC Test Environment



Over the last decade integrated electronics for satellite on-board applications have been continuously gaining importance. Contemporary Application Specific Integrated Circuits (ASICs) or Field Programmable Gate Arrays (FPGAs) comprise the functionality of several Printed Circuit Boards (PCBs) as they were state-of-

the-art ten years ago. Moreover, PCBs designed for today's on-board applications normally host several such ASICs and FPGAs.

Nevertheless, the stringent rules for design and verification of Space Electronics have remained unchanged, leading to a non-linear growth of verification cost with increasing Integrated Circuit (IC) complexity. On the other hand, the prices that can be achieved per PCB have even decreased.

As most of the electronics equipment supplied by Austrian Aerospace contains ASICs or FPGAs, the competitiveness of the company is considerably affected by the efficiency with respect to design and verification, in particular the verification of highly Integrated Circuits.

The Generic ASIC Test Environment (GATE), that has been developed in the present project, is a tool for the time-saving and cost-effective verification and validation of ASICs and FPGAs for satellite on-board electronics. (Figure 1)

An example of a technologically outstanding ASIC, foreseen to be tested with the help of the test equipment emerging from the present activity, is a novel ASIC for Data Handling Systems shown in Figure 2, to be used as highly recurring building block for the up-coming generation of on-board computers.

Another example is a SpaceWire Router ASIC (SPROUT), an Integrated Circuit facilitating wormhole routing between SpaceWire nodes at bit rates of up to 200 Mbit/s. This ASIC development was an initiative of the European Space Agency, aiming at providing an Application Specific Standard Product (ASSP) as standardized building block for modern on-board data networks.

Infobox

Project duration:

09.01.2006 – 08.03.2007

Coordinator:

Austrian Aerospace

www.space.at

Gerald Kempf

1120 Wien, Stachegasse 16

gerald.kempf@space.at

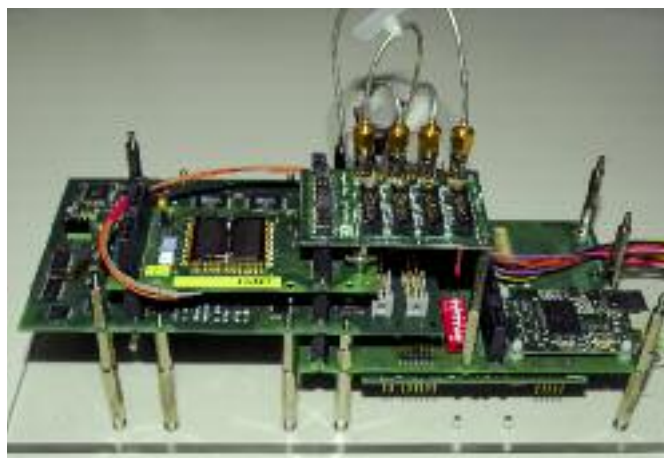

LEO-SLR

Improved kHz-SLR Tracking Techniques and Orbit Quality Analysis for LEO-Missions

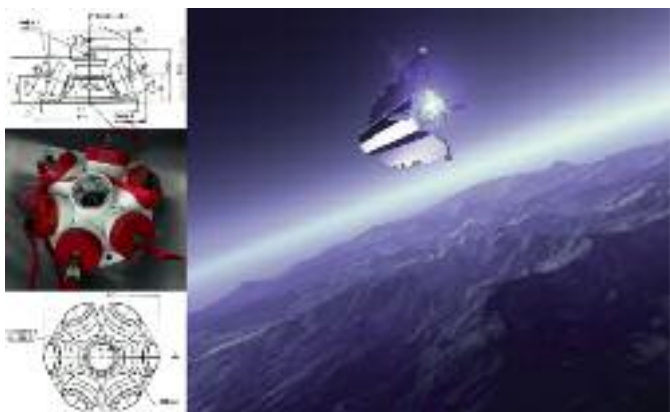

Numerous present and future satellite missions, such as CHAMP and GOCE, are dedicated to provide valuable data for many Earth science related disciplines. Earth observation missions in general and gravity field sensors in particular are naturally designed as low Earth orbiting spacecraft (LEO) with orbit heights of about 200-500 km. In order to fulfil the challenging mission objectives, the precise knowledge of the satellite orbit in space becomes a crucial concern. For these missions precise orbit information is normally provided by GPS / SST observations supported by satellite laser ranging (SLR).

The role of SLR is primarily devoted to serve as an independent external tracking instrument used to calibrate and validate the on-board microwave tracking system. However, the very limited visibility of LEOs from SLR ground stations combined with the accordingly high angular rates of the satellite passes make it very difficult to track LEO missions. At the Lustbühel Observatory the Space Research Institute of the Austrian Academy of Sciences operates a very novel SLR facility which was continuously upgraded during recent years and is today the only station worldwide capable of operating at kHz-firing rates.

The latest improvements focus on a number of further hardware upgrades and methodical improvements of the SLR facility aiming for a faster and utmost reliable target acquisition. These include upgrades of laser tracking algorithms as well as a redesign of the laser detection package tailored to LEO spacecraft. This increases the number of observations per pass and further improves the normal point accuracy as well as the overall system performance for LEO tracking, such as the pointing accuracy or the range gate control.

Another task addresses both, a geometric and dynamic arc comparison of SLR derived orbits with GPS/SST orbit solutions. The resulting one-way SLR range residuals obtained from

Infobox

Project Duration:

1.7.2006 – 31.12.2008

Coordinator / Project Lead:

Institute of Space Research
Austrian Academy of Sciences
Walter Hausleitner
8042 Graz, Schmiedlstraße 6
Mail: walter.hausleitner@oeaw.ac.at
www.iwf.oeaw.ac.at

Partners:

Institute of Navigation and Satellite Geodesy (INAS)
Graz University of Technology
Roland Pail
A-8010 Graz, Steyrergasse 30/III
Mail: pail@geomatics.tu-graz.ac.at
www.inas.tugraz.at

CHAMP allow to draw conclusions on the precision of orbit solutions. Investigations are carried out in an analogous manner by means of simulated GOCE SLR observations. An approach for a quality check of gravity field solutions by means of the detection of inaccurate potential coefficients is outlined, based on simulated GOCE orbits, succeeding gravity field solutions and SLR observations, respectively.

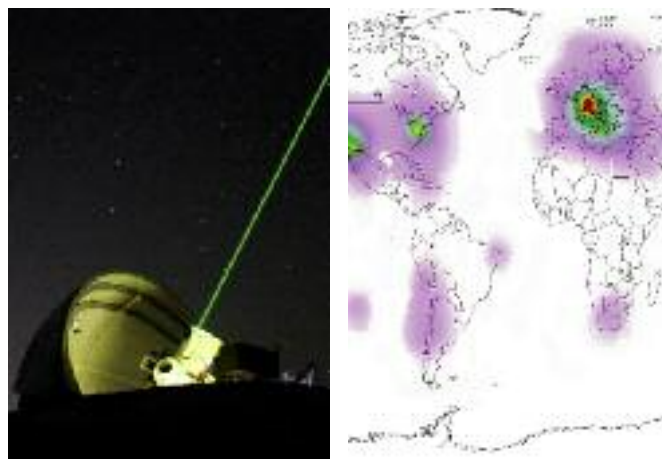

SALOTTE

Solar Array Drive Mechanism (SADM) – Long Term Testing Chamber

“SALOTTE” is the design name for a test equipment to test components used for solar array drive mechanisms. The ASAP-project aims at the development of such a facility. The key target is the combination of certain test parameters relevant to SADM-components and long test durations (weeks to months). Examples of such components are electrical slip-rings, motors, harmonic drives or position sensors. The test equipment shall make it possible to answer questions from basics on material up to long-term behaviour of components. Image 1 shows the actual design of the test equipment: two vacuum chambers are necessary.

An example for “basics” is the following: to optimise slip-rings or potentiometers, it is necessary to measure friction force and electrical contact resistance in a single contact. This not only requires very special geometries, small loading forces are also needed which cannot be simulated correctly by conventional tribometers. Having learned from the basics, new components can be manufactured and also tested: SALOTTE will take up whole slip-rings-assemblies, run them with servo or stepper motors, and measure electrical contact resistance of up to 40 channels. Testing under temperatures from -100 up to 300°C can be done. SALOTTE may also be used for testing harmonic drive gears. Therefore, a second “breaking” motor can be attached to the gear in order to simulate the load of a solar panel. The image 2 shows the mechanical setup for the testing of gears. This new test device will enlarge the service of the “Test house for space materials”. It will be used for testing components for eg BepiColombo.

For this mission even in space high temperatures up to 300°C are expected. Therefore, new concepts on materials and design need to be developed and tested.



Infobox

Project duration:

01.08.2007 – 31.07.2008

Coordinator:

Austrian Research Centers (ARC)

www.arcs.ac.at

Dr. Andreas Merstallinger

A-2444 Seibersdorf

Mail: andreas.merstallinger@arcs.ac.at

International Partners:

Schleifring AG

Harmonic Drive AG

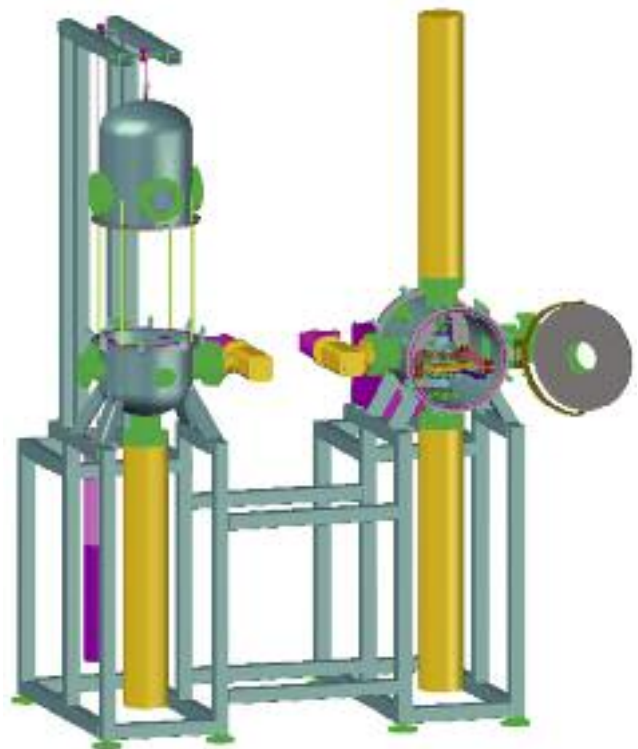

USI – Phase 1

Unbrennbare Superisolation (USI) – Phase 1



Based on the multi-layer insulation technology for spacecraft, this technology transfer project, "Unbrennbare Superisolation (USI) – Phase 1" focuses on the development of a novel, inert multi-layer thermal insulation, which satisfies the applicable requirements and standards for cryogenic vessels used for storage and transport of liquefied technical gases such as He, Ar, N₂ and O₂, with respect to oxygen compatibility.

In different work packages the cornerstones for the "Unbrennbare Superisolation – Phase 2" project are prepared. The requirement specifications for different applications are now well defined and adapted to the requirements of major cryogenic device suppliers.

Calorimeter measurements have been conducted at AAE on samples of non-flammable Superinsulation with a variation of residual gas pressures and boundary temperatures. Thermal models of the calorimeter and the sample were established to allow a confirmation and correct interpretation of these measurements. Gas flows through narrow gaps at low pressure in Superinsulation packages were measured and the impact of residual gas in Superinsulation packages was determined.

A diploma thesis to determine the effect of directional angular emissivity and absorptivity was performed in the framework of USI and provided additional information considering the effects to emissivity at very low temperatures.

The scientific partners, the Austrian Research Institute for Chemistry and Technology (OFI) and the Vienna University of Technology / Institute of General Physics contributed their strength in the fields of chemistry, physics and the theory of combustion, extinction and fire dynamics.

The above results were presented at the CEC-ICMC 2007 (USA) and published in Cold Facts, the journal of the Cryogenic Society of America.

Infobox

Project duration:

01.02.2007 – 30.06.2008

Coordinator:

Austrian Aerospace GesmbH, Michael Neuhäuser

www.space.at

A-1120 Vienna, Stachegasse 16

Mail : michael.neuhaeuser@space.at

Partner:

Vienna University of Technology

Institut für Allgemeine Physik, Herbert Störi

www.iap.tuwien.ac.at

ofi – Österreichisches Forschungsinstitut für Chemie und Technik, Martin Englisch

www.ofi.at



VEDW

Versatile Electronics for Digitally Generated Waveforms

Generators of complex waveforms are key elements of a variety of space applications, as for example spaceborne radars, today implemented on national satellite missions such as Terrasar X or Cosmo-SkyMed and planned to be accommodated on radar satellites of international programs such as the European GMES (Global Monitoring for Environment and Security) initiative.

The functional and performance requirements applied to such signal generators are steadily pushed to the limits of what is feasible with the current state-of-the-art space technology. The availability of new components and technologies, and the aggravated performance requirements inhibit designs for new signal generator applications to be based on heritage to a wide extent.

In addition to the technical challenges space projects have to comply with other challenging constraints such as tight schedules and low budgets.

The present project has aimed at developing the critical building blocks of a Versatile High-end Signal Generator which can be used directly or only with few necessary modifications for a variety of applications. This approach has allowed Austrian Aerospace to acquire competence with new technologies and space components so the challenging technical problems can be solved in an innovative and forward-looking manner.

Saab Space of Sweden, as an international partner to the project, has contributed to this increase in know-how.

Infobox

Project duration:

02.01.2006 – 15.06.2007

Coordinator:

Austrian Aerospace

www.space.at

Walter Hoermanseder

1120 Wien, Stachegasse 16

walter.hoermanseder@space.at

International Partner:

Saab Space

Gothenburg, Sweden

www.space.se

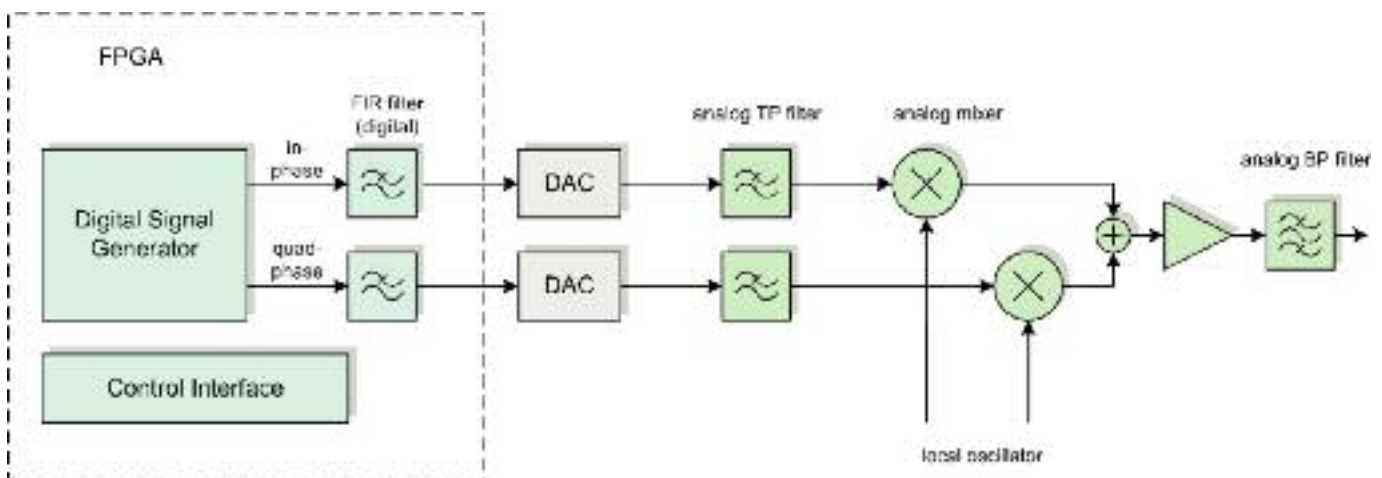

Telecommunications

CASIMO2

GS M&C

NEST

SIECAMS BOX

CASIMO2

Carrier Signal Monitoring

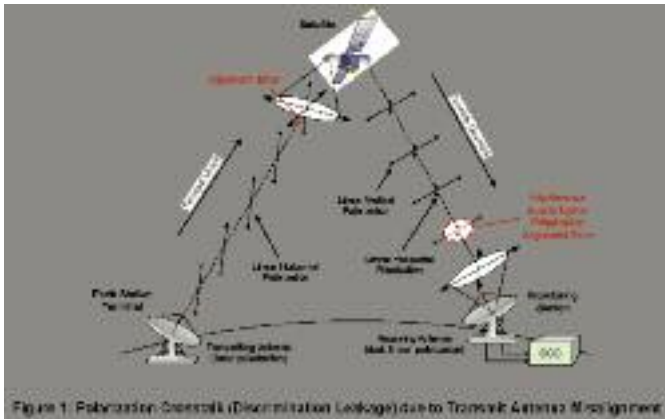

Siemens Space Business has developed a product, called SIECAMS (Siemens Carrier Monitoring System) for the monitoring of the signal spectrum transmitted via satellites, which is already in use at some major satellite operators. The product uses commercially available measurement equipment, which limits measurement speed and accuracy at rather significant equipment costs.

CASIMO2 is a seamless enhancement of the carrier monitoring system based on and driven by customer requirements concerning the implementation of DSP based polarization discrimination measurements combined with enhanced demodulation functionality and satellite performance measurements.

Most of the big satellite providers in the world are developing from a pure transponder capacity provider to a complete service provider. From this point of view and taking into account the new demands for providing bi-directional satellite services to more and more people (Internet access, video on demand, DVB-RCS, voice over IP, etc.) the numbers of customers directly accessing the space segment will continuously increase. Due to these additional services and the increasing number of satellite channels the needs of satellite providers will dramatically change. The realization of this project enables satellite operators and service providers to supply their customers with sustained quality of service and enhanced security against interference and continuously monitoring the health status of the spacecraft transponders.

The main goal associated with this topic was to investigate DSP based demodulation functionalities in order to provide hidden carrier analyses and polarization discrimination measurements based on correlative signal processing techniques.

Infobox

Project duration:

May 2006 – June 2007

Coordinator:

Siemens AG Österreich
Siemens IT Solutions and Services PSE
Aerospace Industry Solutions
1101 Vienna, Gudrunstrasse 11, Austria
phone: +43 (0)51707 42632
FAX: +43 (0)51707 52902
mobile: +43 (0)676 3638526
e-mail: Erwin.greilinger@siemens.com
www.siemens.at/space

Partners:

- 1) Joanneum Research, Graz
- 2) Department of Communication Networks and Satellite Communication (Institut für Kommunikationsnetze und Satellitenkommunikation) IKS at the Technical University in Graz



All parts are implemented and supported by SIECAMS in order to provide novel and highly sophisticated signal analyses functionality and spacecraft transponder performance measurements to the customer. It should be mentioned that in contrast to other systems the polarization discrimination measurements and signal under carrier functionality will finally work during regular operation without any interruption and / or interference to existing services. From an operational point of view this will represent an unattained advantage compared with the capabilities of other systems.

The goal of this project is to design and develop basic components for a generic, state-of-the-art Monitoring and Control (M&C) System for monitoring and controlling both hardware equipment and running software applications.

The architecture of this generic M&C system shall take into account the ESA EGOS architecture, as described in the

- EGOS Framework
to evaluate and apply emerging technologies like
- Reference Model for Open Distributed Processing (RM-ODP)
- Open Services Gateway Initiative (OSGI), Corba Component Model (CCM)
- Eclipse RCP
- Model Driven Architecture (MDA)
- Service Oriented Architecture (SOA)

Modelling and development approach reflect the directives of the EGOS Modelling Framework.

In addition to these requirements and to allow smooth migration, the architecture of existing M&C Systems of ESA is also taken into account. Open and standardised (e.g. SNMP) external interfaces shall allow easy integration into any existing Ground Segment / Ground Station Hardware Infrastructure.

In view of the manifold system requirements, the first phase of the project comprises analysis of existing systems and frameworks, software requirements definition, technology selection, system design.

The second project phase is focussing on detailed UML design of the main components such as Data Description, Data Image, Data Processing, Logging, GUI Server and Client, Equipment Access, Parameter Database and Analyser.

The third project phase is dedicated to implementation and testing of component prototypes.

Infobox

Project duration:

19.02.2007 – 12.05.2008

Coordinator:

Siemens AG Österreich
Siemens IT Solutions and Services PSE
Aerospace Industry Solutions
1101 Wien, Gudrunstraße 11, Austria
Bernhard Moser
Phone: +43 51707 42585

Partner:

Connex CC Di Hadek GmbH
1060 Wien, Nordbahnstrasse 56/DG2
Austria



The Power Subsystem Special Check-Out Equipment (SCOPE) is a central component of the Electrical Ground Support Equipment. It provides power and control signals to the satellite during assembly, testing and launch preparation until just a few seconds prior to lift-off. The activity aims at reducing the manufacturing complexity of the overall Power SCOPE system emphasising standardised components (leading to reduced costs and improved reliability) and making the system operator's user interface more intuitive (leading to easier operations procedures and to a high acceptance by the test engineers).

The approach started with an in-depth analysis of the present system architecture in the areas of hardware architecture, control architecture and user interface, comparing a variety of alternatives in a comprehensive manner. The alternatives are carefully assessed, thus identifying possible areas of improvement. Feedback and advice has been obtained from external experts and customers on the envisaged changes. The outcome is an improved detailed hardware design and manufacturing documentation, a prototype consisting of central modules controlled by the newly embedded controller, and an improved Power SCOPE application software together with a fully functional Power SCOPE SW prototype with simulation of non-existent hardware.



Infobox

Project duration:

March 2007 – May 2008

Coordinator:

Siemens AG Österreich

Siemens IT Solutions and Services PSE

Aerospace Industry Solutions

1101 Vienna, Gudrunstrasse 11, Austria

phone: +43 (0)51707 42654

FAX: +43 (0)51707 52902

mobile: +43 (0)676 77 95 022

e-mail: wolfgang.mader@siemens.com

www.siemens.at/space

The most important requirements for the power SCOPE can be summarized as follows:

- **Flight hardware safety:**
The safety of the flight hardware, even in the presence of a HW or SW failure in the SCOPE or operator error, is of utmost importance. Hence, it requires primary protection in the power supplies themselves as well as secondary protection features that are implemented in the SCOPE HW, and the SCOPE SW is only used for configuration and monitoring purposes.
- **Operating Modes:**
To allow an efficient use of the SCOPE hardware during all stages of spacecraft assembly, integration and validation, the SCOPE operators need to be able to control the SCOPE elements both in a low-level, ad-hoc mode for troubleshooting as well as in a (configuration-) controlled mode for verification and regression testing of the complete onboard system. Therefore the SCOPE software can be operated in two major modes: local and remote. Remote commands are sent via the CCS communication interface while local commands are controlled over the GUI.
- **Power SCOPE Self Test and Validation:**
In order to verify the operational status of the Power SCOPE equipment and functions, a self test facility shall be provided that can be activated at any time to verify the operability of the SCOPE instruments and devices and therefore shall consist mainly of internal self test calls in order not to disturb the momentary S/C interface configuration and state.
- **Launch site switchover between Nom/Red Rack (COMMUTATION):**
Commutation between Nominal/redundant rack must be performed for different interfaces of the SCOPE.

SIECAMS BOX

Carrier Monitoring System for Small Operators

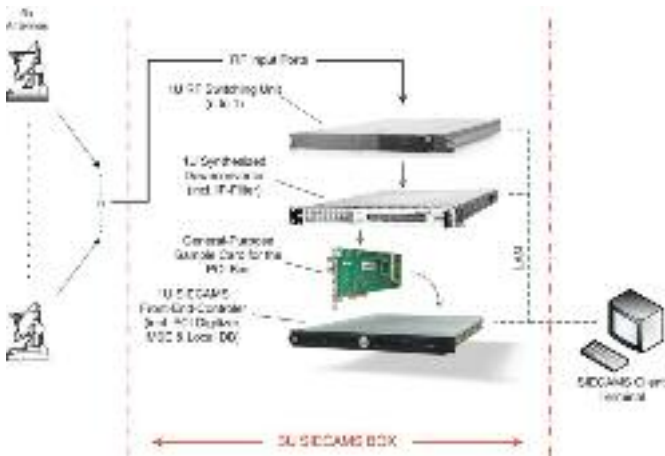

Figure 1: Picture of SIECAMS BOX equipped with PCI

During slice 1 of the Austrian Space Program Joanneum Research and Siemens jointly developed a very powerful and cost efficient DSP based monitoring equipment, which interacts with the Siemens Satellite Monitoring System SIECAMS. This was the key for a successful bid for a European Satellite Provider Hellasat who needed this system for the provision and monitoring of Radio / TV Broadcast services for the Olympic Games in Athens in 2004. In slice 2 of the Austrian Space Program the DSP based monitoring system was enhanced with new functionalities and increased performance. In addition, the capabilities of enhanced polarization discrimination measurements, based on correlative signal processing techniques have been investigated together with enhanced demodulation functionalities providing hidden carrier spectrum (error vector magnitude spectrum) and blind scanning measurements.

In order to perform the relevant post data processing algorithms for providing hidden carrier and blind scanning measurements, SIECAMS needs to access the digitized complex baseband signal (I/Q samples) provided by recently available COTS measurement equipment. Since these devices are stand-alone instruments consuming considerable amount of space (height of 4 U min.), it currently is not possible to offer the whole monitoring functionality housed in a small box (SIECAMS BOX), which comprises at least one measurement device, the SIECAMS FEC and RF Switching Unit.

Apart from the requested savings in space the current design, which needs baseband I/Q samples from a dedicated measurement device, does not allow significant savings of costs especially in case high bandwidth demodulation measurements are requested. E.g. in case the customer needs more than 50

Infobox

Project duration:

June 2007 – May 2008

Coordinator:

Siemens AG Österreich
Siemens IT Solutions and Services PSE
Aerospace Industry Solutions
1101 Vienna, Gudrunstrasse 11, Austria
phone: +43 (0)51707 42632
FAX: +43 (0)51707 52902
mobile: +43 (0)676 3638526
e-mail: Erwin.greilinger@siemens.com
www.siemens.at/space

Partner(s):

- 1) Joanneum Research, Graz,
- 2) Department of Communication Networks and Satellite Communication at the Technical University in Graz

MHz of instantaneous demodulation bandwidth (what is provided by more and more satellite transponders and carriers) the costs for a measurement device will easily double the SIECAMS license fee. Therefore, the SIECAMS BOX intends to integrate the associated equipment functionality in a small 19 inch box of max. 3 U height providing considerable cost savings.

The aim of the project is

- The integration of general-purpose PCI sample cards in SIECAMS for supporting standard spectrum monitoring and demodulation measurement tasks on a highly competitive level in terms of performance and price as well as a reduction of the required equipment space.
- Furthermore, it is the aim of the project to provide a generic interface to import digitized data of different resolution and sampling rates in order to support standard digitization equipment from different manufacturers.
- The current SIECAMS Client Server architecture will be enhanced by an additional Web-Server hosting the web-application.

The architecture, being HW and SW related, will be demonstrated in terms of a prototype implementation which will be the basis for the product called SIECAMS BOX intended both for the low-cost and high performance market segment.



ERA-STAR Regions

Austria (BMVIT, FFG) participates in ERA-STAR Regions, which is a network of public funding organisations which support programmes in the field of Space Applications. It is a 4-year project (start 2004) carried out within the ERA-NET scheme of the 6th Framework Programme of the European Commission.

ERA-STAR Regions started in November 2004 with the objective to co-ordinate R&D management and funding activities in the field of applications related to GALILEO, GMES, and other technologies (such as satellite technologies, launcher concepts, human space flight, exploration and exploitation of space, etc.) in the participating regions/countries, with the final goal of launching joint calls for proposals.

The ERA-STAR Regions network unites 12 European regions and medium-sized countries that have accomplished particular competences in space research. In these regions, the space sector has a high technological profile and is, to varying degrees, interwoven with the regional industrial and research landscape.

The ERA-STAR Regions network links research programme managers from these regions in order to build the transregional critical mass in RTD capacity needed to meet the growing opportunities that space programmes and space-based services offer. Each partner configures its own existing programmes in reference to the following four main themes:

- GALILEO Applications
- GMES Applications
- Technology Applications (GALILEO, GMES, and others)
- Outreach, Education-Related Partnership, Communication

The overall aim of ERA-STAR Regions is to prepare transnational calls to promote cooperation within the space sector in Europe. The first transnational call has been launched in 2007. Austria is involved in the following two projects:

GaWaLoc (Galileo Wagon Locating System)

CONSORTIUM

- Thales Rail Signaling Solutions GesmbH (Austria – Coordinator)
- SELSYS (Austria)
- Fraunhofer (Bavaria)
- TriaGnoSys (Bavaria)
- Kayser-Threde (Bavaria)

First goal of the project is an independent tracking system without being reliant on any infrastructure operators information. Additionally, an accurate localization is required.

GMES – Downstream Service Land: Austria-Slovenia-Andalusia

CONSORTIUM

- JOANNEUM RESEARCH, Institute of Digital Image Processing (Austria -Coordinator)
- GEOVILLE (Austria)
- Umweltbundesamt (Austria)
- GIS Styria (Austria)
- Scientific Research Centre of the Slovenian Academy of Sciences and Arts, Institute for Anthropological and Spatial Studies (Slovenia)
- Slovenian Forestry Institute (Slovenia)
- Slovenian Environmental Agency (Slovenia)
- Environment Ministry of the Regional Government of Andalusia (Andalusia)

The project aims at developing a concept for a cross-border (AU-SLO) land cover/land use (LC/LU) information system.

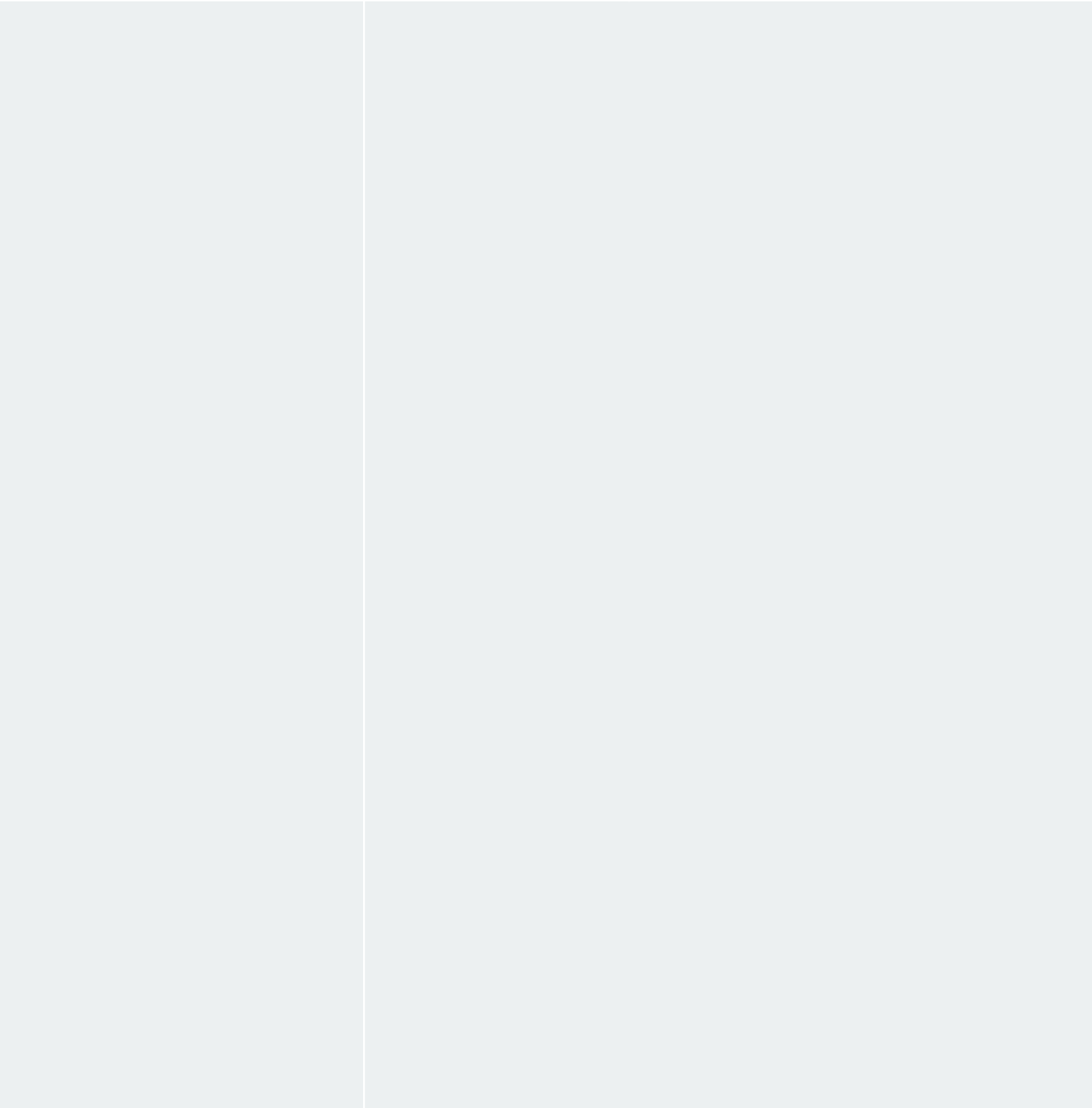

Contacts

Programme responsibility

BMVIT – Federal Ministry for Transport,
Innovation and Technology
Andrea KLEINSASSER
A-1010 Vienna, Renngasse 5
Phone: + 43 1 711 62 65 2904
Fax: +43 1 711 62 65 2013
E-mail: andrea.kleinsasser@bmvit.gv.at



Programme management

Austrian Research Promotion Agency
Aeronautics and Space Agency
Harald POSCH
A-1090 Vienna, Sensengasse 1
Phone: +43 (0)5 7755 3001
Fax: +43 (0)5 7755 79700
E-mail: harald.posch@ffg.at



**More information and relevant documents:
www.ffg.at**

Published by

Federal Ministry for Transport, Innovation and Technology
A-1010 Vienna, Renngasse 5 www.bmvit.gv.at

Design & Produktion:
Projektfabrik Waldhör KEG
Photos: Project partners of the BMVIT, ESA, Projektfabrik

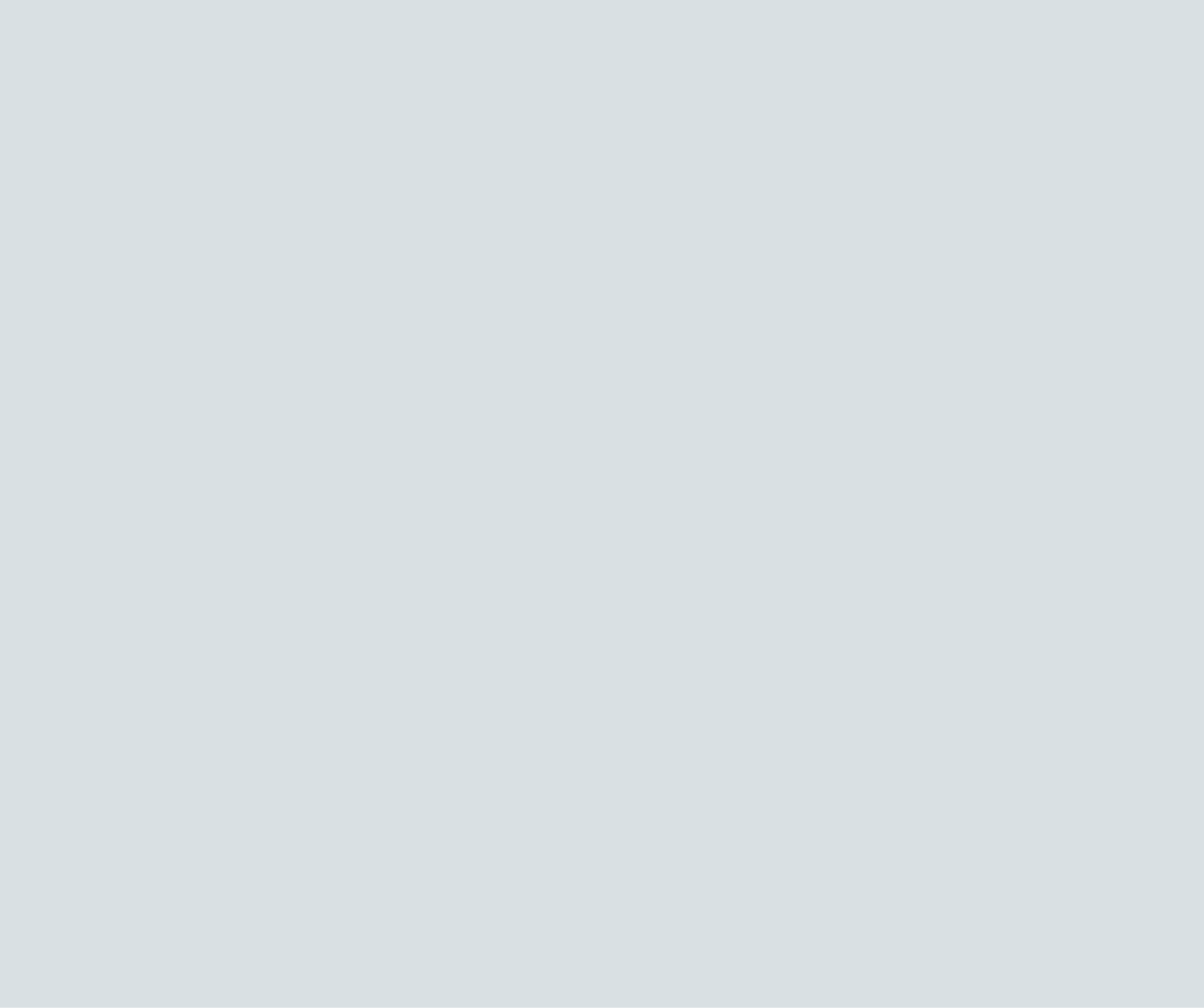

Photo: ESA/BepiColombo

